

National Fenestration  
Rating Council

---

# **NFRC 500: Procedure for Determining Fenestration Product Condensation Index Values** ©

# NFRC 500: Procedure for Determining Fenestration Product Condensation Index Values

---

Copyright 2000 NFRC

Approved:	
Published:	

*Prepared by:*

**National Fenestration Rating Council Incorporated  
1300 Spring Street, Suite 500  
Silver Spring, Maryland 20910  
Telephone: 301-589-NFRC  
Facsimile: 301-588-0854  
E-mail: [NFRCUSA@aol.com](mailto:NFRCUSA@aol.com)  
Web Site: <http://www.nfrc.org>**

## Foreword

The Condensation Index procedure has been developed by the National Fenestration Rating Council (NFRC) to provide consumers, code specifiers, architects, engineers and manufacturers a uniform and accurate means of comparing the resistance to the formation of condensation on fenestration products. The Condensation Index procedure has been developed for use by NFRC-accredited Simulation Laboratories, NFRC-accredited Testing Laboratories and NFRC laboratory inspector(s). The CI established by this procedure is determined at a fixed set of environmental conditions for rating purposes, and therefore may not be appropriate for the determination of the actual occurrence of condensation under all conditions. This document contains the state-of-the-art procedure at the time of its publication. This procedure will be updated, as new research results become available and accepted.

Questions on the use of this procedure should be addressed to:

National Fenestration Rating Council  
1300 Spring Street, Suite 5000  
Silver Spring, MD 20910  
Telephone: 301-589-NFRC  
Facsimile: 301-588-0854  
Email: NFRCUSA@aol.com  
Web Site: <http://www.nfrc.org>

***Table of Contents***

1. Preface..... 1

2. Scope..... 2

3. Terminology ..... 3

4. Simulation Procedure for Determining Fenestration Product Condensation Index Values..... 4

5. Test Procedure for Determining Fenestration Product Condensation Index Values..... 13

6. Referenced Documents ..... 19

Appendix A - Background on the NFRC Condensation Index (CI) ..... 20

Appendix B - Predetermined Temperature Measurement Locations ..... 22

**1. Preface**

This is the first edition of the NFRC Condensation Index procedure and includes information from ASTM C1199, ASTM E1423, NFRC round robin testing data, and technical interpretations by NFRC. The Condensation Index procedure includes a Simulation Method and a Test Method.

The NFRC Simulation Method is presented in Section 4 of NFRC 500. The Simulation Method is based upon the NFRC-approved software tools and is to be used in conjunction with NFRC 100 and the NFRC Simulation Manual.

The Test Method is presented in Section 5 of NFRC 500. The document references the NFRC Test Procedure for Measuring the Steady-State Thermal Transmittance of Fenestration Systems, which contains in its entirety ASTM C1199, as well as modifications adopted by NFRC.

The Test Method has been developed to be a supplement to the Simulation Method. Those products that cannot be simulated for Condensation Index shall use the test procedure to determine a Condensation Index. The Test Method replicates, as closely as possible, the Simulation Method for Condensation Index, but simulated and tested Condensation Index values may not be identical. The simulations are being validated with tested U-factors, as obtained using the NFRC 100 procedure and not with tested Condensation Index values.

This procedure may involve hazardous materials, operations and equipment. This standard does not purport to address all of the safety problems associated with its use. It is the responsibility of the user of this procedure to establish appropriate health and safety practices and to determine the applicability of any regulatory limitations prior to use.

The values stated in metric (SI) units are to be regarded as the standard. The inch-pound (IP) units shown in parenthesis are for reference only.

---

## **2. Scope**

### **2.1. Fenestration Products Covered by NFRC 500**

- a) This procedure provides a Condensation Index (CI) rating for windows, doors, curtain wall systems, site-built products, skylights and other fenestration products;
- b) This procedure refers to the Condensation Index of a fenestration system installed vertically in the absence of solar and air leakage effects; and
- c) The Condensation Index is determined for a single set of environmental conditions. The CI value is a comparative rating that indicates a product's ability to resist the formation of condensation. Since the Condensation Index is a comparative rating, it may not be appropriate for the determination of the actual occurrence of condensation under a given set of environmental conditions.

### **2.2. Fenestration Products and Effects Not Covered by NFRC 500**

- (a) Exterior glazing condensation or between glazing layer condensation;
- (b) Thermal performance changes of a fenestration product over the course of time, i.e., long term energy performance;
- (c) The impact of air leakage and degradation in performance of fenestration products are not covered in this procedure;
- d) Condensation Index of products with attachments is not covered by this procedure.

---

### **3. Terminology**

**Condensation Index (CI):** is a relative indicator of a fenestration product's ability to resist the formation of condensation at a specific set of environmental conditions. The higher the CI value the greater the resistance to the formation of condensation.

- (a) **Frame Condensation Index (CI<sub>f</sub>):** the Condensation Index for the frame portion of the fenestration product.
- (b) **Center-of-Glass Condensation Index (CI<sub>c</sub>):** the Condensation Index for the central portion of the glazing (i.e., part of glazing where 1-D heat transfer effects dominate). The CI<sub>c</sub> also includes divider and divider-edge portions of the product.
- (c) **Edge-of-Glass Condensation Index (CI<sub>e</sub>):** the Condensation Index for the edge portion of the glazing (i.e., part of glazing where 2-D heat transfer effects dominate).
- (d) **Product Condensation Index (CI):** the lower of the CI<sub>f</sub>, CI<sub>c</sub>, and CI<sub>e</sub>.
- (e) **Dew point temperatures (t<sub>dp</sub>):** temperatures at which gaseous water vapor condenses to liquid water at the given relative humidity (RH).
- (f) **Condensation reference point temperatures (t<sub>dpp</sub>):** the dew point temperature plus 0.3°C (0.5°F).

## **4. Simulation Procedure for Determining Fenestration Product Condensation Index Values**

### **4.1. Significance and Use**

- (a) This simulation method shall consist of 2-D heat transfer simulation of the same cross-sections used for U-factor determination as specified by NFRC 100, or the latest applicable standard.
- (b) Since both temperature and surface air film conditions affect results, this simulation procedure requires the use of standardized environmental conditions. The standardized simulation conditions for determining the Condensation Index of vertical fenestration systems are specified below.

#### NFRC Simulation Conditions:

- Interior ambient temperature of 21°C (70°F).
- Exterior ambient temperature of -18°C (0°F).
- Relative Humidities of 30%, 50%, and 70% RH providing condensation reference point temperatures of approximately 2.9°C (37.3°F), 10.3°C (50.6°F) and 15.4°C (59.8°F)
- Wind speed of 7 m/s (15 mph)
- Mean radiant temperature is equal to the exterior ambient air temperature.

Note: The environmental simulation conditions stipulated above are for the purpose of comparative ratings between products.

- (c) The Condensation Index of a specimen shall be determined at the sizes specified in NFRC 100 Table 1.
- (d) This simulation method shall be used to determine the Condensation Index, provided the simulations have been validated under NFRC 100. If the product has been deemed a test only product under NFRC 100 the CI test procedure (Section 5) shall be used to determine the Condensation Index.

## **4.2. Simulation Method**

### **4.2.1 Product Simulation Requirements**

The fenestration system is to be simulated in accordance with NFRC-approved software tools that include a detailed gray-body diffuse radiation model and detailed convection modeling inside all glazing cavities.

### **4.2.2 Determination of Surface Segments**

For each 2-D cross-section, the developed boundary at the indoor surface needs to be subdivided into smaller segments, no larger than the size of mesh or grid used by the simulation program. These segments will be used to compute the product of segment lengths and temperature difference used in the Condensation Index rating calculations. In addition, the total length for each 2-D cross-section shall be calculated.

### **4.2.3 Condensation Index Rating**

The Condensation Index (CI) shall be determined for the total fenestration product from the lower of the condensation indices for the frame  $CI_f$ , edge-of-glass  $CI_e$  and center-of-glass  $CI_c$ .

## **4.3 Condensation Index Calculations**

The following section defines the method of calculating the Condensation Index from simulation data.

- (a) Determination of the resistance of the fenestration product to the formation of condensation in any form, referred to as the Condensation Index, shall be accomplished using the criteria listed in Section 4.1b.
- (b) The Condensation Index using this procedure shall be determined using Equations 1, 2 and 3.

**4.3.1 Determine Condensation Index of the frame,  $CI_f$ .**

Temperatures of the frame sections shall be determined for each subdivided segment (see Section 4.2.2), as an average for that segment, using the approved 2-D simulation program. For each condensation reference point temperature, the product of each segment length and the temperature difference ( $t_{dpp}-t_f$ ), shall be determined and summed for all positive values. This sum shall be divided by the product of total frame segment lengths,  $L_f$  and the difference between the condensation reference point temperature and the outside temperature ( $t_{dpp}-t_o$ ) and calculated for the three relative humidities (i.e., condensation reference point temperatures) for each cross-section. The final  $CI_f$  for each relative humidity shall be calculated by area weighting these non-dimensional numbers for the whole frame area as given in Equation 1.

$$CI_f = \left\{ 1 - \left\{ \frac{\sum_k SS_{f_k} * A_{f_k}}{A_f} \right\}^{1/3} \right\} * 100 \quad (1)$$

$k$  = frame section

where for each frame cross-section,  $k$ :

$$SS_{f_k} = \frac{\sum_j (S_f)_{j=RH @ 30\%, 50\%, 70\%}}{3}$$

where for each relative humidity:

$$S_f = \frac{\sum_i (t_{dpp} - t_f)^+ * \Delta L_{f_i}}{(t_{dpp} - t_o) * L_f}$$

$i$  = subdivided element

$+$  = positive values only

#### **4.3.2 Determine Condensation Index of the Glazing portion, $CI_c$ and $CI_e$ .**

The glazing Condensation Index is split into two components: the edge-of-glass and the center-of-glass. The center-of-glass Condensation Index also includes the divider and divider-edge areas, if applicable.

**Center-of-Glass:** Determine if the interior surface of the center-of-glass area is above or below the three prescribed condensation reference point temperatures at 30% ( $j=1$ ), 50% ( $j=2$ ) and 70% ( $j=3$ ) relative humidity. If the interior surface is at or below the condensation reference point temperature use the entire center-of-glass area for  $A_{cog,j}$ . If the interior surface temperature is above the condensation reference point temperature then use 0 for  $A_{cog,j}$ .

**Dividers:** True divided lites, simulated divided lites and between glass dividers are included in the center-of-glass condensation index,  $CI_c$ . If the glazing system contains between glass dividers, and the space between the divider and glass is less than 3 mm (1/8 in.), divider and divider-edge values need to be calculated. Temperatures of the divider and divider-edge sections shall be determined for each subdivided segment (see Section 4.2.2), as an average for that segment, using the approved 2-D simulation program. For each condensation reference point temperature, the product of segment length,  $\Delta L$  and the temperature difference ( $t_{dpp}-t_d$ ) and ( $t_{dpp}-t_{deog}$ ) shall be determined and summed for all positive values. This sum shall be divided by the product of the divider width,  $L_d$  or divider-edge width,  $L_{deog}$  (i.e., 63.5 mm [2.5 in]) and difference between the condensation reference point temperature and the outside temperature ( $t_{dpp}-t_o$ ). These calculated quantities shall be reported for the three relative humidities (i.e., condensation reference point temperatures) for each unique divider cross-section.

The final  $CI_c$  shall be calculated by area weighting these non-dimensional numbers for the center-of-glass, divider, and divider-edge areas as given in Equation 2.

$$Cl_c = \left\{ 1 - \left\{ \frac{\sum_k SS_{d_k} * A_{d_k} + \sum_k SS_{deog_k} * A_{deog_k} + \sum_k SS_{cog_k} * A_{cog_k}}{\sum_k A_{d_k} + \sum_k A_{deog_k} + \sum_k A_{cog_k}} \right\}^{1/3} \right\} * 100 \quad (2)$$

k = center – of – glass, divider, divider – edge sections, respectively

where for each cross-section, k:

$$SS_{d_k} = \frac{\sum_j (S_d)_{j=RH @ 30\%, 50\%, 70\%}}{3}$$

$$SS_{deog_k} = \frac{\sum_j (S_{deog})_{j=RH @ 30\%, 50\%, 70\%}}{3}$$

$$SS_{cog_k} = \frac{\sum_j (S_{cog})_{j=RH @ 30\%, 50\%, 70\%}}{3}$$

where for each relative humidity, j:

$$S_d = \frac{\sum_i (t_{dpp} - t_{d_i})^+ * \Delta L_{d_i}}{(t_{dpp} - t_o) * L_d}$$

*i* = subdivided element

<sup>+</sup> = positive values only

$$S_{deog} = \frac{\sum_i (t_{dpp} - t_{deog_i})^+ * \Delta L_{deog_i}}{(t_{dpp} - t_o) * L_{deog}}$$

*i* = subdivided element

<sup>+</sup> = positive values only

$$S_{cog} = \frac{\sum_i (t_{dpp} - t_{cog_i})^+}{(t_{dpp} - t_o)}$$

*i* = subdivided element

<sup>+</sup> = positive values only

**Edge-of-Glass:** Temperatures of the edge-of-glass sections shall be determined for each subdivided segment (see Section 4.2.2), as an average for that segment, using the approved 2-D simulation program. For each condensation reference point temperature, the product of segment length and temperature difference ( $t_{dpp}-t_{eog}$ ) shall be determined and summed for all positive values. This sum shall be divided by the product of total edge-of-glass length (i.e., 63 mm [2.5 in.]) and difference between the condensation reference point temperature and the outside temperature ( $t_{dpp}-t_o$ ) and calculated for three relative humidities (i.e., condensation reference point temperatures) for each cross-section.

The final  $Cl_e$  shall be calculated by area weighting these non-dimensional numbers for the edge-of-glass areas as given in Equation 3.

$$Cl_e = \left\{ 1 - \left\{ \frac{\sum_k SS_{eog_k} * A_{eog_k}}{\sum_k A_{eog_k}} \right\}^{1/3} \right\} * 100 \quad (3)$$

$k = \text{edge - of - glass sections, respectively}$

where for each cross-section,  $k$ :

$$SS_{eog_k} = \frac{\sum_j (s_{eog})_{j=RH @ 30\%, 50\%, 70\%}}{3}$$

where for each relative humidity,  $j$ :

$$S_{eog} = \frac{\sum_i (t_{dpp} - t_{eog_i})^+ * \Delta L_{eog_i}}{(t_{dpp} - t_o) * L_{eog}}$$

$i = \text{subdivided element}$

$^+ = \text{positive values only}$

#### **4.3.3 Determine Condensation Index of the Total Product, $Cl$ .**

$Cl = \text{Lower of the } Cl_f, Cl_c, \text{ and } Cl_e$

#### 4.3.4 Condensation Index Variables

- $t_{dp}$  = Dew point temperatures at the given relative humidity (RH);
- $t_{dp,1} = 2.9^{\circ}\text{C}$  (37.3°F) @ RH = 30%
- $t_{dp,2} = 10.3^{\circ}\text{C}$  (50.6°F) @ RH = 50%
- $t_{dp,3} = 15.4^{\circ}\text{C}$  (59.8°F) @ RH = 70%
- $t_{dpp}$  = condensation reference point temperatures,  
 $t_{dpp} = t_{dp} + 0.3^{\circ}\text{C}$  ( $t_{dpp} = t_{dp} + 0.5^{\circ}\text{F}$ )
- $t_{dpp,1} = 3.2^{\circ}\text{C}$  (37.8°F)
- $t_{dpp,2} = 10.6^{\circ}\text{C}$  (51.1°F)
- $t_{dpp,3} = 15.7^{\circ}\text{C}$  (60.3°F)
- $t_o$  = exterior ambient temperature (-18°C)
- $t_{f_i}$  = average temperature of the frame segments  $i$ , subdivided as per 4.2.2,
- $t_{eog_i}$  = average temperature of the edge-of-glass segments  $i$ , subdivided as per 4.2.2,
- $t_{cog_i}$  = average temperature of the center-of-glass area  $i$ ,
- $t_{deog_i}$  = average temperature of the divider-edge area  $i$ ,
- $t_{d_i}$  = average temperature of the divider area  $i$ ,
- $\Delta L_{f_i}$  = length of subdivided segments on each modeled frame cross-section
- $\Delta L_{eog_i}$  = length of subdivided segments on each modeled edge-of-glass cross-section
- $\Delta L_{deog_i}$  = length of subdivided segments on each modeled divider-edge cross-section
- $\Delta L_{d_i}$  = length of subdivided segments on each modeled divider cross-section
- $L_f$  = total (wetted) length of each modeled frame cross-section,
- $L_{eog}$  = total length of each modeled edge-of-glass cross-section,
- $L_{deog}$  = total length of each modeled divider-edge

- cross-section,
- $L_d$  = total length of each modeled divider cross-section,  $A_{cog_k}$  = center-of-glass area of section  $k$ ,
- $A_{f_k}$  = projected frame area of each modeled section on the interior surface
- $A_{eog_k}$  = edge-of-glass area of each modeled cross-section on the interior surface
- $A_{cog_k}$  = center-of-glass area of each modeled center-of-glass section on the interior surface
- $A_{d_k}$  = divider area of each modeled divider cross-section on the interior surface
- $A_{deog_k}$  = divider-edge area of each modeled divider section on the interior surface
- $A_f$  = Total projected area of the frame on the interior surface
- $i$  = index denoting divided sub-segments on indoor boundary
- $j$  = Index denoting relative humidity considered  
 $j = 1$ ; RH=30%  
 $j = 2$ ; RH=50%  
 $j = 3$ ; RH=70%
- $k$  = Index denoting edge-of-glass, frame (i.e. jamb, sill, head, meeting rail, etc.), or center-of-glass sections
- $Cl_f$  = Condensation Index of the frame
- $Cl_c$  = Condensation Index of the center-of-glass area, including, divider, and divider-edge
- $Cl_e$  = Condensation Index of the edge-of-glass area
- $Cl$  = Condensation Index of the Specimen

#### **4.4 Simulation Report**

The simulation report shall include all of the information specified in the NFRC LAP and subsequent NFRC LAP Bulletins.

The report shall include the total product Condensation Index rating value,  $CI$ ; the frame Condensation Index,  $CI_f$ ; the center of glass Condensation Index,  $CI_c$  and the edge of glass Condensation Index,  $CI_e$ , as determined using this simulation procedure. The simulation report shall include all SS values for each cross section.

## **5. Test Procedure for Determining Fenestration Product Condensation Index Values**

### **5.1. Significance and Use**

- (a) This test method references the calibration and testing procedures as defined in the NFRC Test Procedure for Measuring the Steady-State Thermal Transmittance of Fenestration Systems, and necessary additional temperature instrumentation required for the NFRC Test Procedure to measure the Condensation Index of vertical fenestration systems.
- (b) Since both temperature and surface air film conditions affect results, this test procedure requires the use of standardized environmental conditions. The standardized test conditions for determining the Condensation Index of vertical fenestration systems are specified below.

#### NFRC Test Conditions:

- Interior ambient temperature of  $21^{\circ}\text{C} \pm 0.3^{\circ}\text{C}$  ( $70^{\circ}\text{F} \pm 0.5^{\circ}\text{F}$ ).
- Exterior ambient temperature of  $-18^{\circ}\text{C} \pm 0.3^{\circ}\text{C}$  ( $0^{\circ}\text{F} \pm 0.5^{\circ}\text{F}$ ).
- The test sample shall not exhibit any form of condensation on its surfaces during testing.
- An interior measured film coefficient during CTS panel calibration testing of  $8.3 \text{ W/m}^2\cdot\text{C}$  ( $1.35 \text{ Btu/hr}\cdot\text{ft}^2\cdot\text{F}$ )  $\pm 5\%$ .
- An exterior measured film coefficient during CTS panel calibration testing of  $29 \text{ W/m}^2\cdot\text{C}$  ( $5.1 \text{ Btu/hr}\cdot\text{ft}^2\cdot\text{F}$ )  $\pm 10\%$ .

Note: The environmental test conditions stipulated above are for the purpose of comparative ratings between products.

- (c) This test method does not include procedures to measure the Condensation Index due to either air movement through the test specimen or solar radiation effects.
- (d) The Condensation Index of a test specimen may be

affected by its size and three-dimensional geometry. Therefore, it is mandatory that fenestration systems be tested at the sizes specified in NFRC 100.

- (e) This test method is only to be used when the product can not have the Condensation Index simulated using an NFRC Condensation Index Simulation Method per Section 4 of this procedure.

## **5.2. Test Method**

### **5.2.1 Test Specimen Testing Requirements**

The fenestration system is to be tested in accordance with Section 6 of the NFRC Test Procedure for Measuring the Steady-State Thermal Transmittance of Fenestration Systems with the additional thermocouples applied to the interior surface of the product as defined in Appendix B of this procedure.

### **5.2.2 Determination of Total Exposed Surface Area**

The fenestration total wetted surface area shall be used.

### **5.2.3 Temperature Measurement**

The fenestration system is to be instrumented in accordance with Section 6 of the NFRC Test Procedure for Measuring the Steady-State Thermal Transmittance of Fenestration Systems.

- (a) All measurements specified in NFRC Test Procedure shall be made.
- (b) The attachment of thermocouples shall be performed using a nominal 25 mm (1 in.) wide by 100 mm (4 in.) long adhesive-backed flat-white, or equal emittance, aluminum foil tape with the 100 mm (4 in.) dimension parallel to the thermocouple wire.

## **5.3 Test Procedure Calculations**

### **5.3.1 General Calculations**

This section defines the method of calculating the Condensation Index from test data.

- (a) Determination of the resistance of the fenestration product to the formation of condensation in any form, referred to as the Condensation Index, shall be accomplished using the criteria listed in Section 5.1b.
- (b) The Condensation Index using this procedure shall be determined as follows.
- Record interior surface temperature for each individual thermocouple location.
  - Calculate the wetted area assigned to each individual surface thermocouple sensor.
  - Calculate the total interior wetted area of frame and glass.
  - Determine Condensation Index of the frame,  $Cl_f$ , center of glass,  $Cl_c$ , and of the edge of glass,  $Cl_e$ , using Equations 4, 5, and 6:

$$Cl_f = \left\{ 1 - \left[ \frac{\sum_{j=1}^3 \left[ \frac{\sum_i (t_{dpp,j} - t_{f_i})^+ * A_{f_i}}{(t_{dpp,j} - t_o) * A_f} \right]_{j=RH @ 30\%,50\%,70\%}}{3} \right]^{1/3} \right\} * 100 \quad (4)$$

*i = frame thermocouples*

$$Cl_c = \left\{ 1 - \left[ \frac{\sum_{j=1}^3 \left[ \frac{\sum_i (t_{dpp,j} - t_{g_i})^+ * A_{c_i}}{(t_{dpp,j} - t_o) * A_c} \right]_{j=RH@30\%,50\%,70\%}}{3} \right]^{1/3} \right\} * 100 \quad (5)$$

*i = center – of – glass, divider, and divider – edge thermocouples*

$$Cl_e = \left\{ 1 - \left[ \frac{\sum_{j=1}^3 \left[ \frac{\sum_i (t_{dpp,j} - t_{eog_i})^+ * A_{eog_i}}{(t_{dpp,j} - t_o) * A_{eog}} \right]_{j=RH@30\%,50\%,70\%}}{3} \right]^{1/3} \right\} * 100 \quad (6)$$

*i = edge – of – glass thermocouples*

### 5.3.2 Determine Condensation Index of the Total Product, *Cl*.

*Cl* = Lower of the *Cl<sub>f</sub>*, *Cl<sub>c</sub>*, and *Cl<sub>e</sub>*

### 5.3.3 Condensation Index Variables

*t<sub>dp,j</sub>* = Dew point temperatures at the given relative humidity (RH);

*t<sub>dp,1</sub>* = 2.9°C (37.3°F) @ RH = 30%

*t<sub>dp,2</sub>* = 10.3°C (50.6°F) @ RH = 50%

*t<sub>dp,3</sub>* = 15.4°C (59.8°F) @ RH = 70%

*t<sub>dpp,j</sub>* = condensation reference point temperatures,

*t<sub>dpp</sub>* = *t<sub>dp</sub>*+0.3°C (*t<sub>dpp</sub>* = *t<sub>dp</sub>*+0.5°F)

*t<sub>dpp,1</sub>* = 3.2 °C (37.8°F)

*t<sub>dpp,2</sub>* = 10.6 °C (51.1°F)

*t<sub>dpp,3</sub>* = 15.7 °C (60.3°F)

- $t_o$  = exterior ambient temperature (-18°C)
- $t_{f_i}$  = individual frame thermocouple temperatures.
- $t_{g_i}$  = individual glazing (center-of-glass, divider, and divider-edge) thermocouple temperatures.
- $t_{eog_i}$  = individual edge-of-glass thermocouple temperatures.
- $A_{f_i}$  = wetted interior area represented by the frame thermocouples
- $A_{c_i}$  = interior area represented by the central part of glazing (i.e., center-of-glass, divider, and divider-edge) thermocouples
- $A_{eog_i}$  = interior area represented by the edge-of-glass thermocouples
- $A_f$  = Total (wetted) area of the frame on the interior surface
- $A_c$  = Total area of the central part of glazing (i.e., center-of-glass, divider, and divider-edge) on the interior surface
- $A_{eog}$  = Total area of the edge-of-glass on the interior surface
- $i$  = Index denoting frame, or glazing thermocouple section
- $j$  = Index denoting relative humidity considered  
 $j = 1$ ; RH=30%  
 $j = 2$ ; RH=50%  
 $j = 3$ ; RH=70%
- $Cl_f$  = Condensation Index of the frame
- $Cl_c$  = Condensation Index of the center-of-glass area, including divider and divider-edge
- $Cl_e$  = Condensation Index of the edge-of-glass area
- $Cl$  = Condensation Index of the Specimen

#### **5.4 Test Report**

The report shall include all of the information specified in NFRC Test Procedure, and the NFRC LAP and subsequent NFRC LAP Bulletins. The test specimen size and design shall also be reported. If the test specimen size is non-standard ( $\pm 13$  mm [1/2 in.]) in width and/or height from the model size referenced in Table 1 of NFRC 100, then the text "non-standard size" shall be inserted immediately following the size everywhere the size is listed, both in the full report and in any summary.

The report shall include the total product Condensation Index rating value,  $CI$ ; the frame Condensation Index,  $CI_f$ ; and the glazing Condensation Index,  $CI_g$ , as determined using this test procedure.

In addition, if applicable, the information required in the NFRC Test Procedure for Measuring the Steady-State Thermal Transmittance of Fenestration Systems Section 9.2. The following statement from Section 3.5 of the NFRC Test Procedure must be included in the test report directly after the above results are reported.

"This test method does not include procedures to determine the Condensation Index due to either air movement through the specimen or solar radiation effects. As a consequence, the Condensation Index results obtained do not reflect performance which may be expected from field installations because they do not account for solar radiation, air leakage effects, and the thermal bridge effects that may occur due to the specific design and construction of the fenestration system opening. Therefore, it should be recognized that the Condensation Index results obtained from this test method are for controlled laboratory conditions and should only be used for fenestration product comparisons and as input to condensation resistance performance analyses, which also include solar, air leakage and thermal bridge effects.

---

## **6. Referenced Documents**

### **6.1. NFRC Documents**

- (a) NFRC Test Procedure for Measuring the Steady-State Thermal Transmittance of Fenestration Systems (April 1997); and
- (b) NFRC 100: Procedures for Determining Fenestration Product U-factors (April 1997).

### **6.2 ASTM Standards**

- (a) C1199: Standard Test Method for Measuring the Steady State Thermal Transmittance of Fenestration Systems Using Hot Box Methods, 2000;
- (b) C1363: Standard Method of Test for the Thermal Performance of Building Assemblies by Means of a Hot Box Apparatus, 1997; and
- (c) E1423: Practice for Determining the Steady-State Thermal Transmittance of Fenestration Systems, 1999.

## **Appendix A**

### **Background on the NFRC Condensation Index (CI)**

Reducing or eliminating condensation is one of many fenestration product selection criteria, but an especially important one in cold climates. In addition to the aesthetic issue of reduced visibility or window view, condensation can cause damage to curtains, carpets and wall finishes, cause mold and wood rot, lift paint and plaster, and eventually result in damage to building materials. Water contact with insulating glass sealant may result in premature failure of the edge seals.

The formation of condensation on the interior surfaces of fenestration products is dependent on a number of factors including the outdoor temperature, and the relative humidity inside the building. As the outside temperature falls, the indoor surface temperature of the fenestration product falls below the interior dew point temperature. The interior dew point temperature is a function of the relative humidity of the interior air. The higher the relative humidity, the higher the dew point temperature. This means that with the same fenestration product surface temperature conditions, condensation will occur sooner in a space with a higher indoor relative humidity. Measured winter relative humidity levels in buildings vary between 20 and 70 percent.

The NFRC Condensation Index (CI) scale is 1-100, with a higher number being better. The CI is determined based on outside conditions of -18°C (0°F) with a 7 m/s (15 mph) wind, and inside conditions of 21°C (70°F) with relative humidities of 30%, 50%, and 70%. The CI is a value that considers the relative area of condensation at the three humidities and the degree to which the surface temperatures are below the dew point for the frame and for the glazing. The CI specified in the NFRC rating is based on the lower of the frame or glazing value.

The Condensation Index is determined for very specific conditions. When installed in a building, there are numerous uncontrolled, site specific factors that may affect the condensation formation on the fenestration product, including installation details, site geometry, wind speed and direction, air circulation and fenestration product coverings,

to name a few. In this procedure, the Condensation Index is meant to apply only to interior fenestration product surfaces under cold winter conditions. The procedure does not address the issue of condensation on the exterior fenestration product surface as can occur during seasons other than winter.

Appendix B

Predetermined Temperature Measurement Locations

This Appendix indicates the correct placement of thermocouples when testing for Condensation Index. All thermocouples intended to measure center-of-glass temperature shall be placed at the center-of-glass of each unit in the fenestration product. All thermocouples intended to measure edge-of-glass temperature shall be placed 13 mm (1/2") from the sightline of the frame along the centerline of the fenestration product. All thermocouples intended to measure frame temperatures shall be placed along the centerline of the fenestration product at a location that will be representative of the area weighted average temperature of the frame segment represented by the thermocouple. There are many different kinds of fenestration products covered by this procedure, including many different frame materials and designs. The exact placement of frame thermocouples will require the operator to make some judgment in the position of the thermocouples.

Figure B-1: Casement and Awning Thermocouple Placement

(Awning - rotate 90 degrees)

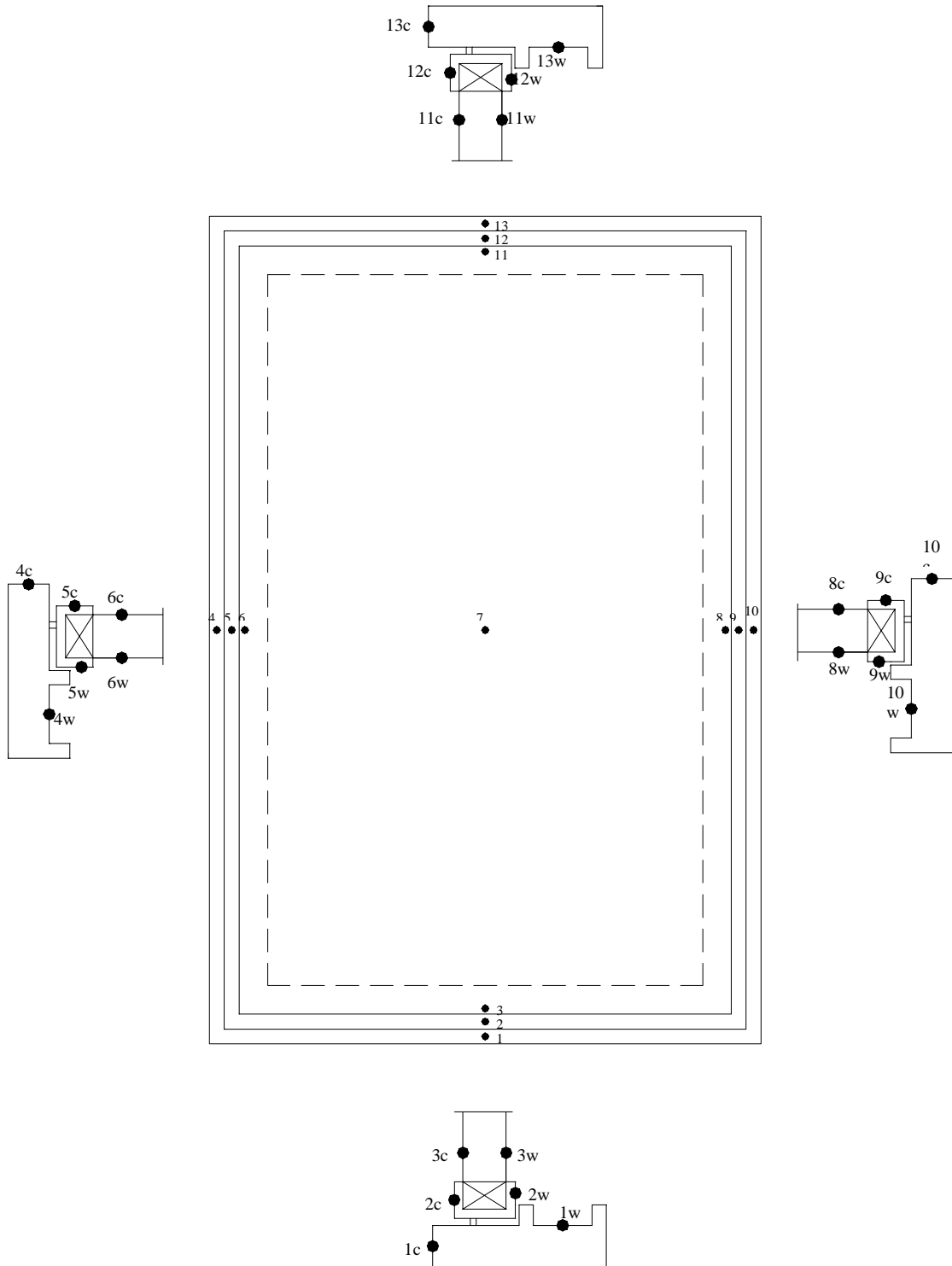
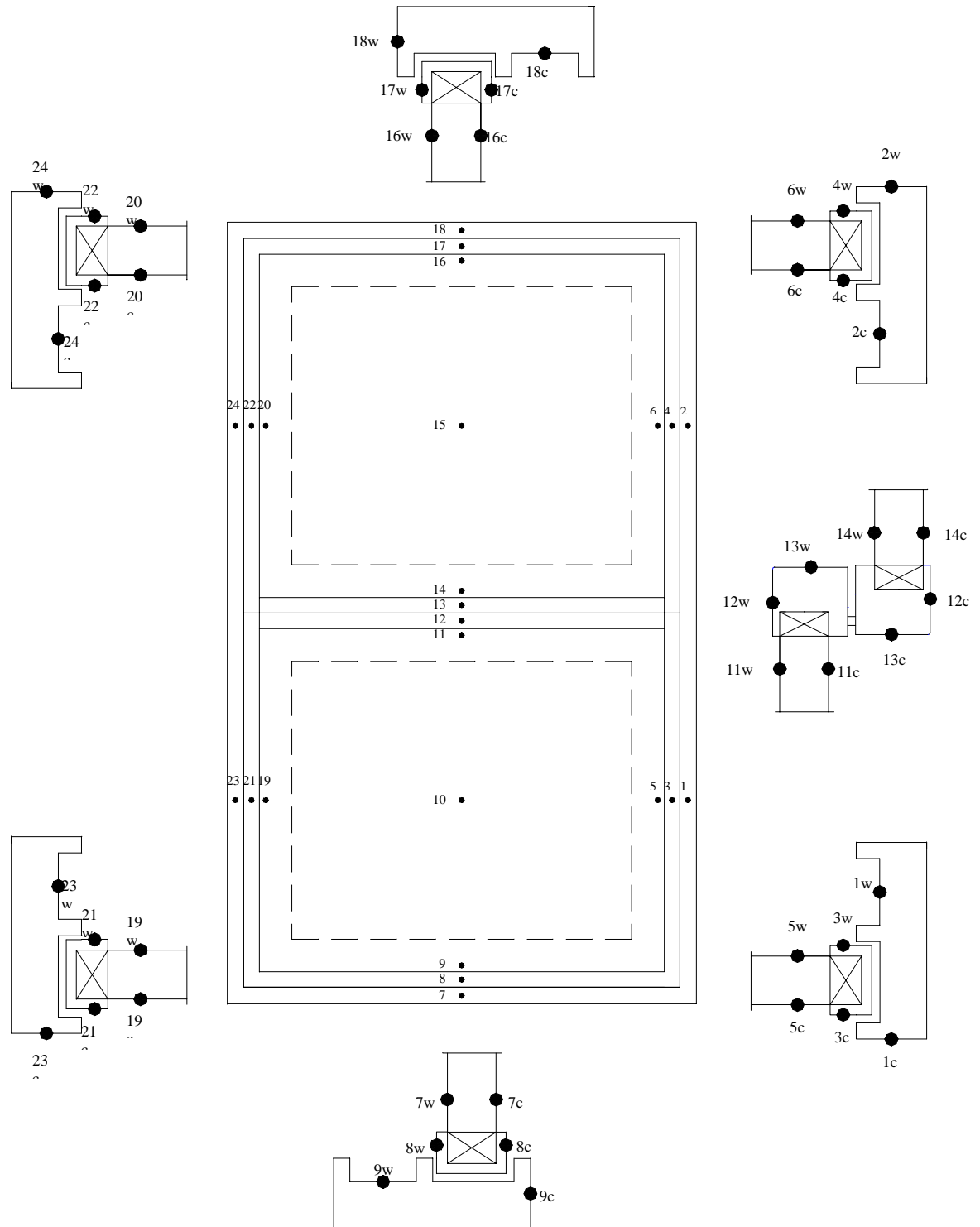

Figure B-2: Fixed Window, Sidelite, and Transom  
Thermocouple Placement

Figure B-3: Swinging Patio Door  
Thermocouple Placement

Figure B-4: Horizontal Slider, Vertical Slider, and Sliding Patio Door  
Thermocouple Placement  
(Vertical Slider – rotate 90 degrees)



**Figure B-5: Glazed Wall and Sloped Glazing  
Thermocouple Placement**

Figure B-6: Divider  
Thermocouple Placement

