

**NFRC/CSA-A100:  
PROCEDURE FOR DETERMINING  
FENESTRATION PRODUCT THERMAL INDICES<sup>1</sup>**

**PRELIMINARY DRAFT  
(18 April 2001)**

***DRAFT 0.h  
(18 April 2001)<sup>2</sup>***

**Comments are due by 6 July 2001. To obtain an electronic copy of the comment form, or to view or download this document on line, please go to one of the following websites:**

- **NFRC website at [nfrc.org](http://nfrc.org)**
- **CSA website at [www.csa-international.org](http://www.csa-international.org)<sup>3</sup>**

---

<sup>1</sup> Explanatory information is included in footnotes. This material is for review only. It is intended to be removed from the final document.

<sup>2</sup> To be deleted prior to release for public review.

<sup>3</sup> Jeff to provide exact reference from CSA.

**FORM FOR COMMENTING ON A HARMONIZED DOCUMENT**  
**Preliminary Draft of *Procedure for Determining Fenestration Product Thermal Indices***

**PLEASE RETURN COMPLETED FORM BY 6 July 2001.**

**1. Name:**

Affiliation:

Address:

City:

State/Province:

Zip/Postal Code:

Telephone:

Fax:

E-mail:

Date:

**2. Designation and Title of 60 day Harmonized Document:**

**Preliminary Draft of *Procedure for Determining Fenestration Product Thermal Indices***

**NOTE:** Use a separate form for each comment, completing each portion of this form (including Section 1 above) to facilitate separate processing.

**3. Reference Section:**

**4. Comment and Alternative Language:**

**5. Substantiating Statements and Justification:**

NOTE: Use separate form for each comment. Submittals (MS Word preferred) may be attached to email (preferable), submitted on diskettes, or submitted in paper form by mail or fax.

E-mail: *nfrcusa@aol.com*

*larry.gill@csa-international.org*

Mail: John Hogan  
c/o Dan Wise  
National Fenestration Rating Council  
1300 Spring Street, Suite 500  
Silver Spring, MD 20910  
UNITED STATES

Jeff Baker  
c/o Larry Gill  
CSA International  
178 Rexdale Boulevard  
Toronto, ON M9W 1R3  
CANADA

Fax: 301-588-6342

416-747-2473

# Table of Contents

## Preface

1. Scope
  - 1.1 Title
  - 1.2 Intent
  - 1.3 Products Covered
2. Terminology
  - 2.1 Definitions
  - 2.2 Abbreviations and Acronyms
3. Reference Publications
4. Compliance
  - 4.1 General
  - 4.2 Standard Products for Rating Purposes
  - 4.3 Product Line Groupings
  - 4.4 Material Values
  - 4.5 Product Specimens
  - 4.6 Simulation and Test Reports
5. Simulation
  - 5.1 General
  - 5.2 U-factor
  - 5.3 Solar Heat Gain Coefficient (SHGC)
  - 5.4 Visible Transmittance (VT)
  - 5.5 Condensation
6. Testing
  - 6.1 General
  - 6.2 U-factor
  - 6.3 Solar Heat Gain Coefficient (SHGC)
  - 6.4 Visible Transmittance (VT)
  - 6.5 Condensation

**TABLES**

Table 1: Standard Model Sizes and Configurations for Fenestration Products ..... 16  
Table 2: Allowed Divider Height Groupings..... 19  
Table 3: Allowed Divider Pattern Groupings ..... 20  
Table 4: Allowed Glass Thickness Groupings..... 22

**FIGURES**

Figure 1: Window Cross-section ..... 36  
Figure 2: Door Cross-section ..... 37  
Figure 3: Factory Assembled Composite Window Units ..... 38  
Figure 4: Divider Height and Divider Width..... 39  
Figure 5: Thermocouple Placement ..... 40

**APPENDICES**

Appendix A: Approximate I-P Conversions for Information Purposes Only..... 50  
Appendix B: Material Conductivities ..... 53  
Appendix C: Glazing Deflection ..... 60  
Appendix D: Test Data Sheets (Required Information) ..... 61  
Appendix E: Tubular Daylighting Devices..... 64

## **PREFACE**

This is the first edition of NFRC/CSA-A100 *Procedure for Determining Fenestration Product Thermal Indices*. This procedure resulted from an effort to harmonize existing NFRC and CSA International procedures: NFRC 100/200/201/500 and CSA A440/A440.2.

This Standard provides simulation and testing procedures for determining thermal indices including, but not limited to, U-factor, solar heat gain coefficient (SHGC), visible transmittance, and condensation. The scope includes all fenestration products: windows, doors, and skylights.

This Standard was approved by the National Fenestration Rating Council (NFRC) and CSA International (formerly Canadian Standards Association). This Standard will be submitted to the American National Standards Institute (ANSI) for approval as an American National Standard and to the Standards Council of Canada (SCC) for approval as a National Standard of Canada.

This is a metric document. For user information, I-P approximations are included in Appendix A: Approximate I-P Conversions for Information Purposes Only.

## 1. SCOPE

1.1 **Title.** This standard shall be known as the *Procedure for Determining Fenestration Product Thermal Indices* and shall be cited as such. It is referred to herein as “this standard”.

1.2 **Intent.** This standard specifies methodology (ies) for determining fenestration product thermal indices. The indices include, but are not limited to:

- (a) U-factor
- (b) Solar heat gain coefficient
- (c) Visible transmittance
- (d) Condensation.

Where noted in this standard, simplifications are allowed in certain cases when like products have essentially the same performance.

1.3 **Products Covered.** This standard addresses all fenestration products and components unless otherwise indicated in subsequent sections.<sup>4</sup>

- (a) Products of all types<sup>5</sup> (e.g., sliding windows (including vertical and horizontal, hung and non-hung), hinged windows (including casement, awning, hopper, projecting), fixed windows, non-standard shaped and non-rectangular windows, dual action windows, pivoting windows, glazed wall systems (including curtain walls, storefronts, window walls, and solariums), greenhouse/garden windows, bay or bow windows, basement windows, jalousie windows, jal-awning windows, tropical awning windows, tubular daylighting devices, unit skylights, unit roof windows, sloped glazing (glazed roof systems including solariums), exterior door products, both glazed and unglazed, including but not limited to sliding doors, swinging (hinged) doors, fixed doors, and door sidelites and door transoms, revolving doors, vehicular access doors).
- (b) Products of all frame materials used singly or in combination (e.g., aluminum, steel, thermally broken aluminum, thermally improved aluminum, wood, vinyl, reinforced vinyl, fiberglass, foam insulation, plastic, and cellulosic composites).
- (c) Products of all glazing materials, tints, types (e.g., clear glass, tinted glass, stained glass, glass block, thin plastic films (internally suspended, internally applied, or externally applied), rigid plastics, and translucent fiberglass with or without any solar control, low-emissivity or any other partially transparent coating) and products with in-fill panels.
- (d) Products with any or no gap width between glazing layers (e.g., single and multiple glazing, laminated glass).

---

<sup>4</sup> The intent is to have a complete scope. Where modeling or testing limitations currently exist, those are to be indicated in the appropriate subsections. As the modeling and testing capabilities are improved, these limitations will be deleted from the appropriate subsections, rather revising the scope.

<sup>5</sup> To match Table 1: Standard Model Sizes and Configurations for Fenestration Products.

- (e) Products with any spacer or spacer systems between glazing layers (e.g., metallic, non-metallic, or multi-material spacers).
- (f) Products utilizing any true or simulated glazing dividers (e.g., grilles inside or outside, or between glazing layers, muntin bars, true divided lites, or simulated divided lites).
- (g) Products with any gas-fill mixture between glazing layers (e.g., atmospheric air, argon/air, krypton/air, krypton/argon/air).

## 2. TERMINOLOGY

**2.1 Definitions.***Area, center-of-glazing ( $A_c$ ):* all glazed areas except those within 63.5 mm (2.5 in.) of any part of a primary sash and/or frame and/or divider; or any part of a primary door and/or frame and/or divider. See Figure 1: Window Cross-section and Figure 2: Door Cross-section.

*Area, divider ( $A_d$ ):* the projected area in the plane(s) parallel to the product's glazing of all interior or exterior applied non-removable dividers, true dividers, or between glazing dividers. See Figure 1: Window Cross-section and Figure 2: Door Cross-section.

*Area, divider-edge ( $A_{de}$ ):* all glazed vision areas within 63.5 mm of any part of a divider area. The divider edge area shall exclude any edge-of-glazing area contained within the center-of-glazing area. See Figure 1: Window Cross-section and Figure 2: Door Cross-section.

*Area, edge-of-glazing ( $A_e$ ):* all glazed vision areas within 63.5 mm of any part of the frame and sash or of the door lite frame sightline, excluding any area contained in the divider area. The edge-of-glazing area shall exclude any divider area contained within the edge-of-divider area. See Figure 1: Window Cross-section and Figure 2: Door Cross-section.

*Area, frame ( $A_f$ ):* the sum of the projected areas of all frame and sash members in the plane(s) parallel to the glazing surface, summed over each glazing plane; except for doors, which shall include the projected areas of the door jambs, header, threshold, door bottom sweep and the peripheral structural elements of the door leaf, in a plane parallel to the door core surface. See Figure 1: Window Cross-section and Figure 2: Door Cross-section.

*Area, projected fenestration product ( $A_{pf}$ ):* the area of the rough opening in the wall or roof, for the fenestration product, less installation clearances.

*[Note: Where a fenestration product has glazed surfaces facing in only one direction (typical windows), the sum of the divider-edge area, the edge-area, the divider area, the center-of-glass area, and the frame area will equal the total projected fenestration product area ( $A_{pf}$ ). Where a fenestration product has glazed surfaces in more than one direction (e.g., greenhouse/garden, bay/bow windows) the sum of the areas will exceed the projected fenestration product area.]*

**Awning window:** (See **Hinged window, bottom/top – awning, hopper, projecting.**)

**Basement window:** any fenestration product operator type intended only for use at or below grade for the purpose of ventilating a basement or cellar.

**Bay window:** a combination window which is composed of two or more individual windows joined side by side and which projects away from the wall on which it is installed. Center windows, if used are parallel to the wall on which the bay window is installed. The two side windows are angled with respect to the outer window. Common angles are 30 degrees and 45 degrees, although other angles are sometimes employed.

**Bow window:** Rounded bay window that projects from a wall in the shape of an arc.

**Casement window:** (See **Hinged window, side – casement.**)

**Cellulosic composite:** a composite whose ingredients include cellulosic elements. These cellulosic elements can appear in the form of, but are not limited to: distinct fibers, fiber bundles, particles, wafers, flakes, strands and veneers. These elements may be bonded together with naturally occurring or synthetic polymers. Also, additives such as wax or preservatives may be added to enhance performance.

**Center-of-glazing area ( $A_c$ ):** (See **Area, center-of-glazing.**)

**Combination assembly:** a window, door, or skylight assembly formed by a combination of two or more separate units whose frames are mullied together.

**Composite unit:** a window, door, or skylight unit consisting of two or more product types within a single frame utilizing an integral mullion. (Not to be confused with composite materials.)

**Curtain wall:** an external nonbearing wall, intended to separate the exterior and interior environments, which may consist entirely (or principally) of a combination of framing materials, glass and glazing, opaque in-fill and other surfacing materials supported by (or within) a framework, in varying percentages per the design of the system.

**Divider area ( $A_d$ ):** (See **Area, divider.**)

**Divider-edge area ( $A_{de}$ ):** (See **Area, divider-edge.**)

**Door:** (See **Hinged door (swinging); Revolving door; Sliding door; Vehicular access door; Door sidelite; Door transom.**)

**Door sidelite:** a non-operable fenestration product that is typically used as companion product installed on one or both sides of a door. Sidelites may consist of a glazed frame or a non-operable sash within a frame. For purposes of compliance with this standard, sidelites shall not exceed 700 mm in width. For operable fenestration products, see the appropriate operator type.

**Door slab:** a side hinged attachment greater than 700 mm in width whose primary function is to allow human egress. (This is NOT intended for rating windows).

**Door transom:** a non-operable fenestration product that is typically used as companion windows installed above a door. Transoms may consist of a glazed frame or a non-operable sash within a frame. For purposes of compliance with this standard, transoms shall not exceed 700 mm in height. For operable fenestration products, see the appropriate operator type.

**Dual action window:** a fenestration product that consists of a sash that tilts from the top for ventilation and swings inward from the side for cleaning of the outside surface. Dual action windows are sometimes referred to as Tilt-Turn windows.

**Edge-of-glazing area ( $A_e$ ):** (See **Area, edge-of-glazing.**)

**Fixed window:** a non-operable fenestration product and may consist of a glazed frame or a non-operable sash within a frame. This category does not include non-operable skylights. (See **Sash** and **Skylight.**)

**Frame and sash:** any structural member of the fenestration product, with the exception of muntins or other dividers used to create true or artificial divided lites.

**Frame area ( $A_f$ ):** (See **Area, frame.**)

**Garage door:** (See **Vehicular access door.**)

**Glazed wall system:** the non-operable portions of a curtain wall, solarium, storefront, or window wall that are mounted at a slope less than or equal to 15 degrees from the vertical plane. (See **Curtain wall, Solarium, Storefront, or Window wall.** For operable portions, see the appropriate operator type.)

**Glazing:** The glass, plastic or other translucent or transparent material used to enclose openings in a building created by a specific framing system. Opaque in-fill panels are allowed to be substituted for glazing in any of the calculations in this document.

**Greenhouse/garden window:** a fenestration product which consist of a three-dimensional, five-sided structure, with provisions made for supporting plants and flowers in the enclosed space outside the plane of the wall. Operating sash are allowed but are not required.

**Hinged door:** a fenestration product containing one or more operable panels within a common frame. The operable panels are side hinged and are either in-swinging or out-swinging, but not both directions.

**Hinged window:** a fenestration product comprised of a sash that swings inward or outward.

**Hinged window, bottom/top – awning, hopper, projecting:** a fenestration product which has one or more sash hinged at the top or bottom which project outward or inward from the plane of the window in the vertical plane. **Projected windows** have one or more sash hinged at the top or bottom which project outward or inward from the plane of the frame. An **awning** rotates about its top hinge and projects outward. A **hopper window** rotates about its bottom hinge and projects inward. Top Hinged Projecting In and Bottom Hinged Projecting Out are also included in this category. They may contain one or more operable sash, fixed lites, or transoms in various combinations.

**Hinged window, side - casement:** a fenestration product which has one or more sash hinged at the side (adjacent to the jambs) which project outward or inward from the plane of the window in the vertical plane. A conventional casement window rotates about its side hinge and projects outward. Casement windows may contain one or more operable sash, fixed lites, or transoms in various combinations.

**Hopper window:** (See **Hinged window, bottom/top – awning, hopper, projecting.**)

**Horizontal sliding window:** (See **Sliding window, horizontal.**)

**In-fill panel:** opaque insulative panels designed for interchangeability with glazing options.

**Jalousie window:** a fenestration product which consists of a series of overlapping, horizontal frameless louvers which pivot simultaneously in a common frame and are actuated by one or more operating devices so that the bottom edge of each louver swings outward and the top edge swings inward during operation.

**Jal-Awning window:** a fenestration product which consists of a multiplicity of top-hinged sash arranged in a vertical series within a common frame and each operated by its own control device which swings the bottom edges of the sash outward.

**Outdoor Air Ventilator Assembly (OAVA):** An assembly that allows for the exchange of air through the envelope that is an integral part of the fenestration assembly.

**Pivoted window – vertical/horizontal:** a fenestration product comprised of a sash which pivots about an axis within the frame. These windows can be pivoted horizontally or vertically. The pivoting action of the window allows for easy access to clean the outside surfaces of the window. Two common types are the 180-degree compression seal pivoting window and the 360-degree pivoting window. A **180-degree compression seal pivot** rotates about an axis of the sash and frame to permit cleaning of the outside surfaces. After cleaning the window is pivoted back to its closed position where the sash seals against the frame using a compression type seal. A **360-degree pivot** rotates about the midspan of the sash and frame. When pivoted 180 degrees, it may be held for the purpose of cleaning the outside surfaces, it also provides a weather seal in this position. Upon completion of the cleaning operation, the sash can be pivoted another 180 degrees to its normal closed position.

**Product type:** (See **Basement; Bay or Bow; Dual Action; Fixed; Glazed Wall System, vision; Glazed Wall System, opaque spandrel; Greenhouse/garden; Hinged, bottom/top – awning, hopper, projecting; Hinged, side – casement; Jalousie; Jal-Awning; Pivoted – vertical/horizontal; Sliding, horizontal; Sliding, vertical – hung & non-hung; Tropical awning;; Hinged door (swinging); Revolving door; Sliding door; Vehicular access door; Door sidelite; Door transom; Skylight; Roof window; Sloped glazing (glazed roof system), Tubular daylighting device.**)

**Projected fenestration product area ( $A_{pf}$ ):** (See **Area, projected fenestration product.**)

**Projecting window:** (See **Hinged window, bottom/top – awning, hopper, projecting.**)

**Revolving door:** An exterior door consisting of two or more leaves which pivot about a common vertical axis within a cylindrically shaped vestibule; prevents the direct passage of air through the vestibule, thereby eliminating drafts from the outside.

**Roof window, unit:** a sloped application of a fenestration product that provides for in-reach operation or rotation of the sash to facilitate cleaning of the exterior surfaces from the interior of the building. This application may also allow for egress situations.

**Sash:** the portion of a fenestration assembly which is installed in a frame and includes the glazing, stiles and rails. Normally, the moving segment of a window, although sash are sometimes fixed. (See also **Frame and sash.**)

**Sidelite, door:** (See **Door sidelite.**)

**Skylight, unit:** a sloped or horizontal application of a fenestration product in an out-of-reach application, which allows for natural daylighting, excluding tubular daylighting devices. (See **Tubular daylighting device.**) Skylights may be either fixed (non-operable) or venting (operating). Unlike roof windows, skylights need not provide provisions for cleaning of exterior surfaces from the interior of the building.

**Skylight:** (See **Skylight, unit; Roof window, unit; Sloped glazing (glazed roof system); Tubular daylighting devices.**)

**Sliding door:** a fenestration product containing manually operated panels which slide horizontally within a common frame. Operating panel (X) and a fixed lite (O) comprising a unit are termed single slide (XO or OX). When two operating panels are separated by a fixed lite, the unit is termed a picture slide or end vent (XOX). When two fixed lites are separated by an operating panel, the unit is termed a center slide (OXO). When two bi-parting panels are located at the center of the unit with fixed lites at each end, the unit is termed a bi-part center slide (OXXO). When adjacent panels by-pass one another, the unit is termed as a double slide (XX, OXX or XXO) or a double slide end vent (XXX).

**Sliding window, horizontal:** a fenestration product which contains manually operated sash which slide horizontally within a common frame. Operating sash (X) and a fixed lite (O) comprising a unit are termed single sliders (XO or OX). When two operating sash are separated by a fixed lite, the unit is termed a picture slide or end vent (XOX). When two fixed lites are separated by an operating sash, the unit is termed a center slide (OXO). When two bi-parting sash are located at the center of the unit with fixed lites at each end, the unit is termed a bi-part center slide (OXXO). When adjacent sash by-pass one another, the unit is termed as a double slide (XX or XXO) or a double slide end vent (XXX).

**Sliding window, vertical – hung and non-hung:** a fenestration product which contains at least one manually operated sash which slides vertically within a common frame. All provisions of testing apply whether there are one, two or three sash which operate. This category has two sub categories which are hung and non-hung windows. **Hung windows** utilize counter-balancing devices to allow the sash to be opened to any variable position between its fully open and fully closed limits. Common types are single hung, double hung and triple hung. **Non-hung windows** utilize mechanical retainers or slide bolts to allow the sash to be opened to any one of the pre-selected positions between its fully open and fully closed limits.

**Sloped glazing (glazed roof system):** a multiple-lite glazed system (similar to a curtain wall) that is mounted at a slope greater than 15 degrees from the vertical plane.

**Solar heat gain coefficient (SHGC):** the ratio of the solar heat gain entering the space through the projected area of a fenestration product to the incident solar radiation under specific environmental conditions. Solar heat gain includes directly transmitted solar heat and absorbed solar radiation, which is then reradiated, conducted, or convected into the space.

**Storefront:** a nonresidential system of doors and windows mullied as composite units or combination assemblies. Typically designed for high use/abuse and strength. The storefront system usually is installed between floor and ceiling.

**Transom, door:** (See **Door transom.**)

**Tropical awning window:** a fenestration product consisting of one or more top-hinged or pivoted sash operated by one control device which swings the bottom edge of the sash

outward. A single control or operating device operates all sash, securely closing them at both jambs without the use of any additional manually controlled latching devices.

***Tubular daylighting devices:*** a device primarily designed to transmit daylight from a roof surface to an interior ceiling surface via a tubular conduit. The device consists of an exterior glazed weathering surface, a light transmitting tube with a reflective inside surface, and an interior sealing device such as a translucent ceiling panel.

***U-factor (a.k.a. U-value):*** a measure of the heat transfer characteristics of a fenestration product under specific environmental conditions. The U-factor multiplied by the interior-exterior temperature difference and by the projected fenestration product area, yields the total heat transfer through the fenestration product due to conduction, convection, and infrared radiation. The U-factor is the heat transmission in a unit time through a unit area of a test specimen and its boundary air films, induced by a unit temperature difference between the environments on each side.

***Vehicular access door:*** a door that is used for vehicular traffic at entrances of buildings such as garages, loading docks, parking lots, factories, and industrial plants, and that is not generally used for pedestrian traffic.

***Vertical sliding window:*** (See **Sliding window, vertical – hung and non-hung.**)

***Visible transmittance (VT):*** the ratio of the visible light entering the space through the projected area of a fenestration product to the incident visible light under specific environmental conditions.

***Window wall:*** a type of curtain wall installed between floors (or between floor and roof) that is typically composed of vertical and horizontal framing members containing operable or ventilators, fixed lights or opaque panels, or any combination thereof in varying percentages per the design of the system.

***Windows:*** (See **Basement; Bay or Bow; Dual Action; Fixed; Glazed Wall System, vision; Glazed Wall System, opaque spandrel; Greenhouse/garden; Hinged, bottom/top – awning, hopper, projecting; Hinged, side – casement; Jalousie; Jal-Awning; Pivoted – vertical/horizontal; Sliding, horizontal; Sliding, vertical – hung & non-hung; Tropical awning.**)

## **2.2 Abbreviations and Acronyms**

*\*\* To be completed in final draft \*\**

### **3. REFERENCE PUBLICATIONS**

#### **Material Properties**

**ASTM C 1114** *Standard Test Method for Steady-State Thermal Transmission Properties by Means of the Thin-Heater Apparatus*

**NFRC 300** *Standard Test Method for Determining Solar and Infrared Optical Properties of Glazing Materials and Systems (2001)*

#### **U-factor**

**ASTM C 177** *Test Method for Steady-State Heat Flux Measurements and Thermal Transmission Properties by Means of the Guarded Hot Plate Apparatus (1997)*

**ASTM C 518** *Test Method for Steady-State Thermal Heat Flux Measurements and Transmission Properties by Means of the Heat Flow Meter (1998)*

**ASTM C 1199** *Standard Test Method for Measuring the Steady-State Thermal Transmittance of Fenestration Systems Using Hot Box Methods (2000)*

**ASTM C 1363** *Standard Method of Test for the Thermal Performance of Building Assemblies by Means of a Hot Box Apparatus (1997)*

**ASTM E 1423** *Standard Practice for Determining the Steady State Thermal Transmittance of Fenestration Systems (1999)*

#### **Solar Heat Gain Coefficient**

**NFRC 201** *Interim Standard Test Method for Measuring the Solar Heat Gain Coefficient of Fenestration Systems Using Calorimetry Hot Box Methods (2000)*

#### **Visible Transmittance**

**ASTM C 1175** *Standard Test Method for Determining Solar or Photopic Reflectance, Transmittance, and Absorptance of Materials Using a Large Diameter Integrating Sphere (re-approved 1996)*

#### **Gas Fill**

**CAN/CGSB-12.8-97** *Insulating Glass Units*

## **4. COMPLIANCE**

**4.1 General.** Fenestration products shall comply with Section 4 and with Sections 5 and/or 6 as follows:

- (a) For the purposes of simulation, products shall be simulated in accordance with Section 5.
- (b) For the purposes of testing, products shall be tested in accordance with Section 6.
- (c) This standard does not preclude a certification program from requiring that either or both simulation and testing be done.

**4.2 Standard Products for Rating Purposes.** Each individual product shall be rated with the exact components in the product except where groupings are required or allowed in 4.3. Products shall be rated using the product type, configuration (opening/non-operating), and size in Table 1: Standard Model Sizes and Configurations for Fenestration Products.

- (a) The sizes indicated in Table 1: Standard Model Sizes and Configurations for Fenestration Products are intended to be representative of all variations in size.
- (b) Dual lite configurations (opening/non-operating) indicated in Table 1: Standard Model Sizes and Configurations for Fenestration Products, are intended to be representative of all variations in configuration with dual or more lites (opening/non-operating) for the product type, except where indicated in the footnotes.
- (c) Individual units within a combination assembly shall be rated separately.
- (d) Factory-assembled composite window units consisting of two product types (one type being a fixed unit and one type being a side-hinged, top/bottom hinged, or sliding) shall be rated as a composite window to the configuration in Figure 3: Factory Assembled Composite Window Units. This represent multiples of each product type provided that there are no more than two product types. Other composite units require a separate rating for each product type within the composite unit.
- (e) Products shall be evaluated without screens, removable grilles, or any other applied devices. Products shall be evaluated in the vertical position except where otherwise indicated in Table 1: Standard Model Sizes and Configurations for Fenestration Products.
- (f) If a product contains an OAVA and the OAVA area does not exceed 1.25% of the area of the fenestration assembly, it is considered to have the same U-factor as the fenestration assembly. If the OAVA area exceeds this percentage, a separate U-factor must be determined for the OAVA and the fenestration assembly.

**Table 1: Standard<sup>6</sup> Model Sizes and Configurations for Fenestration Products**

Fenestration Product Type	Configuration: Opening (X) Non-operating (O)	Model Size: Width x height in mm
<b>Windows</b>		
Basement		See appro. operator type(s)
Bay or bow		See appro. operator type(s)
Dual action	X	1200 x 1500
Fixed (single)	O	1200 x 1500
Fixed (dual)	OO	2000 x 2000
Glazed wall system, vision	OO <sup>1</sup>	2000 x 2000
Glazed wall system, opaque spandrel	OO <sup>1</sup>	2000 x 2000
Greenhouse/garden	X <sup>2</sup>	1200 x 1500 x 300
Hinged, bottom/top – awning, hopper, projecting (single)	X	1500 x 600
Hinged, bottom/top – awning, hopper, projecting (dual)	XX	1500 x 1200
Hinged, side – casement (single)	X	600 x 1500
Hinged, side – casement (dual)	XX	1200 x 1500
Jalousie, Jal-Awning	X <sup>3</sup>	1200 x 1500
Pivoted – vertical/horizontal	X	1200 x 1500
Sliding, horizontal	XX <sup>4</sup>	1500 x 1200
Sliding, vertical – hung & non-hung	XX <sup>4</sup>	1200 x 1500
Tropical awning	X <sup>3</sup>	1500 x 1200
<b>Doors</b>		
Hinged doors (swinging)	X <sup>5,6</sup>	1000 x 2000
Revolving doors	X	2000 x 2000 <sup>7</sup>
Sliding doors	XO <sup>8</sup>	2000 x 2000
Vehicular access doors	X or multiple X	3000 x 2400 <sup>9</sup>
Door sidelites	O <sup>10</sup>	600 x 2000
Door transoms	O <sup>10</sup>	2000 x 600
<b>Skylights<sup>11</sup></b>		
Unit skylights/ roof windows	X <sup>12</sup>	1200 x 1200 <sup>13</sup>
Sloped glazing (glazed roof system)	OO <sup>1</sup>	2000 x 2000
Tubular daylighting device	O	350 <sup>14</sup>

<sup>6</sup> The sizes for the most common products are based on ISO 12567, but rounded to the nearest 100 mm.

## Footnotes to Table 1: Standard Model Sizes and Configurations for Fenestration Products

- <sup>1</sup> Two panels with one vertical mullion. A curtain wall shall be simulated and tested with intermediate verticals as jambs and intermediate horizontals as head/sill frame members. A window wall shall be simulated and tested with standard jamb, head, and sill members. A solarium shall be simulated and tested with standard jamb, head, and sill members.
- <sup>2</sup> Simulate or test the configuration with the greatest number of operable panels. If not manufactured with any operable panels, use O (fixed unit).
- <sup>3</sup> Representative of units with multiple vents.
- <sup>4</sup> Use XO if manufacturer does not make an XX, or OO if manufacturer does not make an XX or XO. XX represents XO and OO, and XO represents OO.
- <sup>5</sup> If the manufacturer makes a single door and a double door, the single shall represent the double door. If the manufacturer only makes a double door, then use 2000 x 2000 mm.
- <sup>6</sup> For manufacturers who provide door slabs only without the frame, the following default frames shall be used for ratings:
  - Wood default frame: 115 mm deep x 20 mm wide softwood single rabbetted frame of 8 to 12% moisture content, with a specific gravity of 0.35 to 0.45, and with a dual durometer plastic compression weatherstrip and flexible sweep. The door sill shall be a standard 115 mm extruded aluminum sill with a wall thickness of 1.4 mm to 1.6 mm with a poured-in-place polyurethane filled and a 3mm debridged thermal break with a conductivity of 0.52 W/m•K<sup>7</sup> without a wood substrate.
  - Steel default frame shall consist of a 145 mm - 16 Ga. pressed steel frame with a minimum 120 mm throat depth, applied weather-strip, and an aluminum non-thermally broken sill with a sill wall thickness of 1.4 mm to 1.6 mm and no substrate. Frame shall consist of a head jamb, hinge jamb, lock jamb, and necessary anchors and reinforcing for hinges and locks. See Figures<sup>8</sup>
- <sup>7</sup> Width dimension is the diameter of the revolving door. Rating to include the heat flow through the  $A_{pf}$  (i.e. the rough opening in the wall) from all components of the revolving door assembly (including the revolving door wings and the walls and roof of the revolving door enclosure). Revolving door to be rated in the closed position (i.e. with the maximum number of enclosed cavities). The frame profiles required to model revolving doors are: head, sill, hub, and one jamb for even number of wings or two jambs for odd number of wings. Glazings shall be modeled with the distance between the glazing set to the average distance between them ( $3.14 \times \text{diameter}/8$ ). Separate ratings are required for various wing configurations (e.g. with two, three, and four wings).
- <sup>8</sup> Use XX where the manufacturer does not make an XO.
- <sup>9</sup> Where ratings are determined by physical testing, test samples are allowed to be 2400 x 2400 mm if the test chamber can not handle the size in the table. However, in all cases, ratings are to be based on 3000 x 2400 mm.
- <sup>10</sup> For operable configurations, rate as the appropriate operator type.
- <sup>11</sup> Ratings to be at a 20 degree slope.
- <sup>12</sup> If not manufactured, use O (fixed unit).
- <sup>13</sup> Fits over a nominal 1180 x 1180 mm rough opening.
- <sup>14</sup> Diameter of tube.

---

<sup>7</sup> Value to correspond with Appendix B.

<sup>8</sup> Need these figures. Marcia to provide.

**4.3 Product Line Grouping.** Groupings are provided as a means of simplifying and reducing the number of ratings. Groupings generally result in a more conservative rating. The use of groupings is optional. In all cases, the reports shall indicate where grouping has been used and what grouping has been done. *(Note that labeling and certification requirements may affect groupings.)*

Groupings shall be done in the order that follows.

#### **4.3.1 Frame Types.**

**4.3.1.1 Base Profile.** Products shall be rated using the actual frame profile for all configurations or grouped with minor product variations required for alternate installation situations (e.g. removable brick moulds, mounting flanges, or jamb extensions). Cladding is considered a different base profile.

**4.3.1.2 Base Profile Reinforcement.** Products shall be rated using the actual frame profiles with and without reinforcement for all configurations or grouped with the frame profile having the highest heat loss.

For simulation, one simulation shall be done for the base profile without reinforcement and additional simulations for each reinforcement system used. Once all reinforcement options have been identified within a product line, the frame and edge-of-glazing heat loss is simulated for each option using a representative cross-section with the lowest center-of-glazing U-factor in the product line. These products can then be grouped with each group represented by the reinforcement group leader which is the option with the highest frame and edge-of-glazing heat loss.

For testing, grouping for reinforcement is not allowed.

**4.3.1.3 Base Frame Material.** Products shall be rated using the actual frame material of the base profile identified in 4.4.1.1 for all configurations or grouped using the highest conductivity.

**4.3.1.4 Outdoor Air Ventilator Assembly:** Products with an outdoor air ventilator assembly (OAVA) in the frame that is 1.25% or more of the frame area shall be rated using the actual OAVA. For products where the OAVA area does not exceed 1.25% of the frame area, the product is allowed to be considered as having the same performance as the same product without an OAVA.

#### **4.3.2 Multiple Glazing Layers.**

**4.3.2.1 Gap Width.** Products shall be rated using the actual gap width for all configurations or grouped using the narrowest gap width.

**4.3.2.2 Gas Fill.** Products shall be rated using the actual gas concentration for all configurations or grouped using 100% air.

**4.3.2.3 Spacer Type.** Products shall be rated using the actual spacer type for all configurations or grouped using the spacer with the highest conductance. The spacer with the highest conductance is identified as follows. Once all spacer options have been identified within a product line, the frame and edge-of-glazing

heat loss is simulated for each option using a representative cross-section with the lowest center-of-glazing U-factor in the product line. These products can then be grouped with each group represented by the spacer group leader which is the option with the highest frame and edge-of-glazing heat loss.

**4.3.2.4 Divider Widths.** Products shall be rated using the actual divider widths for all configurations or grouped using the divider with the highest conductance. The divider with the highest conductance is identified as follows. Once all divider options have been identified within a product line, the frame and edge-of-glazing heat loss is simulated for each option using a representative cross-section with the lowest center-of-glazing U-factor in the product line. These products can then be grouped with each group represented by the divider group leader which is the option with the highest frame and edge-of-glazing heat loss. (See Figure 4: Divider Height and Divider Width.)

**4.3.2.5 Divider Heights.** Products shall be rated using the actual divider heights for all configuration or grouped using the heights in Table 2: Allowed Divider Height Groupings.

**Table 2: Allowed Divider Height Groupings**

<b>Divider Range (DR) number</b>	<b>Divider Height Range (mm)</b>	<b>Represented by Divider Height (mm)</b>
A	$x \geq 25$	40
B	$25 > x$	20

(See Figure 4: Divider Height and Divider Width.)

**4.3.2.6 Divider Patterns.** Products shall be rated using the actual divider patterns for all configuration or grouped using the patterns in

Table 3: Allowed Divider Pattern Groupings.

**Table 3: Allowed Divider Pattern Groupings**

<b>Fenestration Product Type</b>	<b>Number of Grille Bars: Vertical x Horizontal</b>
<b>Windows</b>	
Basement	See appropriate operator type(s)
Bay or bow	See appropriate operator type(s)
Dual action	3 x 4
Fixed (single)	3 x 4
Fixed (dual)	3 x 6 (each lite)
Glazed wall system, vision	3 x 6 (each lite)
Glazed wall system, opaque spandrel	Not applicable
Greenhouse/garden	Not allowed
Hinged, bottom/top – awning, hopper, projecting (single)	4 x 1
Hinged, bottom/top – awning, hopper, projecting (dual)	4 x 1 (each lite)
Hinged, side – casement (single)	1 x 4
Hinged, side – casement (dual)	1 x 4 (each lite)
Jalousie, Jal-Awning	Not allowed
Pivoted – vertical/horizontal	3 x 4
Sliding, horizontal	2 x 3 (each lite)
Sliding, vertical – hung & non-hung	3 x 2 (each lite)
Tropical awning	Not allowed
<b>Doors</b>	
Hinged doors (swinging)	Not allowed
Revolving doors	Not allowed
Sliding doors	3 x 6 (each lite)
Vehicular access doors	Not allowed
Door sidelites	1 x 6
Door transoms	6 x 1
<b>Skylights<sup>11</sup></b>	
Unit skylights/roof windows	Not allowed
Sloped glazing (glazed roof system)	3 x 6 (each lite)
Tubular daylighting device	Not allowed

### 4.3.3 Glass/Film Types.

**4.3.3.1 Glass/Film Thickness.** Products shall be rated using the actual thickness for all configurations or grouped as in Table 4: Allowed Glass Thickness Groupings:

**Table 4: Allowed Glass Thickness Groupings**

<b>Glass Thickness Range (GTR) category</b>	<b>Glass Thickness Range (mm)</b>	<b>Nominal Glass Thickness name</b>	<b>Represented by size (mm)</b>
A	$X \leq 2.0$	film	Actual
B	$2.0 < x \leq 4.5$	2.5, 3.0, 4.0	3.0
C	$4.5 < x \leq 6.5$	5.0, 6.0	6.0
D	$6.5 < x$	8 and larger	Actual

#### 4.4 Material Values

**4.4.1 Material Conductivities.** Material conductivities shall be determined in accordance with Appendix B: Material Conductivities. For materials not listed in Appendix B: Material Conductivities, materials shall be tested in accordance with:

- (a) ASTM C 177 *Test Method for Steady-State Heat Flux Measurements and Thermal Transmission Properties by Means of the Guarded Hot Plate Apparatus.*
- (b) ASTM C 518 *Test Method for Steady-State Thermal Heat Flux Measurements and Transmission Properties by Means of the Heat Flow Meter.*
- (c) ASTM C 1114 *Standard Test Method for Steady-State Thermal Transmission Properties by Means of the Thin-Heater Apparatus*

**4.4.2 Glazing Emittance and Solar Optical Properties.** Glazing emittance and solar optical properties shall be determined in accordance with NFRC 300 *Standard Test Method for Determining Solar and Infrared Optical Properties of Glazing Materials and Systems.*

#### 4.5 Product Specimens.

**4.5.1 Production Line Specimens.** All simulation and/or test samples shall be production line specimens.

**EXCEPTION:** For new products, which are defined as products not in production, the simulation and/or test shall be conducted with a prototype specimen that replicates the expected production line product to the greatest extent possible.

**4.5.2 Size of Specimen.** For simulation, the size dimensions shall be as shown in Table 1: Standard Model Sizes and Configurations for Fenestration Products. For test, the size dimensions shall comply with the least deviation equation for the size in Table 1: Standard Model Sizes and Configurations for Fenestration Products

using the following formula:

$$D = \sqrt{(W_p - W_m)^2 + (H_p - H_m)^2}$$

Where:

D = deviation in mm

$W_p$ ,  $H_p$  = width, height of product test specimen

$W_m$ ,  $H_m$  = width, height of standard size of operator type from Table 1:  
Standard Model Sizes and Configurations for Fenestration Products.

- 4.5.3 Gas Fill.** Simulation specimens shall assume standard air as the gas fill and test specimens shall have standard air as the gas fill, unless the manufacturer demonstrates otherwise per the procedures of **CAN/CGSB-12.8-97 *Insulating Glass Units***.
- 4.5.4 Gap Width.** Simulation specimens shall be assumed to have planar layers with a constant gap width. Test specimens shall have an initial glazing deflection, either concave (collapsed) or convex (over-filled), measured upon arrival at the test laboratory of:
- (a) for products with an edge-of-glazing gap width of 13 mm, a center-of-glazing deflection (concave or convex) of 3 mm or less.
  - (b) for products with an edge-of-glazing gap width of more than 13 mm, a center-of-glazing deflection (concave or convex) of 6 mm or less.
- EXCEPTION:** Products which are intended to have non-planar surface, such as dome skylights.
- (See Appendix C: Glazing Deflection.)
- 4.5.5 Specimen Handling and Processing.** For testing,
- (a) The testing laboratory shall maintain records documenting the condition of the test specimen upon its arrival at the testing facility.
  - (b) The testing laboratory shall notify the manufacturer in writing if the product arrives damaged (i.e. broken glazing, damaged frame/stile or rail components, etc.).
  - (c) Prior to the issuance of a final report, the testing laboratory shall disassemble the test specimen in such a manner after testing in order to verify the description of the product in the test report.
- 4.5.6 Retention of Information.** Simulation/test laboratories shall maintain electronic records of the information used as the basis for the simulation/test index for a period of not less than four years. In addition, the test laboratory shall retain, in a safe and protected location, each whole fenestration product tested or representative corner and cross sections of all the fenestration product components for a period not less than one year after the date a test report is first issued by the laboratory.

## **4.6 Simulation and Test Reports.**

**4.6.1 Contents.** The following material shall be included in all simulation and test reports:

- (a) Name, address, and phone number of simulation/test laboratory.
- (b) Location and identification of simulation program and/or test equipment utilized.
- (c) Simulation/test date.
- (d) Name and address of client.
- (e) Serial number, date or other appropriate means of identifying each individual product report.
- (f) Simulation/test method employed.
- (g) A statement that the simulation/tests were conducted in full compliance with the applicable requirements.
- (h) A bill of materials, assembly drawings, profile drawings, and a description of the specimen including the following ( Note: some items listed may not be applicable in certain cases):
  1. Manufacturer, name of location, and series or model number.
  2. General description of product (operator type, size, framing type, glazing type, spacer type).
  3. Bill of materials including vendor name and part numbers.
  4. Parts drawings (i.e., frame, stile or rail, glazing, hardware, etc.).
  5. Physically measured parameters (sizes and thicknesses measured to 1 mm; i.e., overall window dimensions, operable and/or fixed sash dimensions, glazing daylight openings, and door component parts).
  6. Glazing material(s), including thickness, coatings, and/or internal films (emissivity, if known) and their location (surface) defined from the outside to the inside.
  7. Gap width at the edge-of-glazing, and at the center-of-glazing. For tested specimens, the test laboratory shall measure and report the glazing deflection of the specimen upon initial arrival at the test facility and immediately following the test. The report shall indicate the amount of deflection and whether the deflection is concave (collapsed) or convex (over-filled).
  8. Documented design gas fill concentration and fill method per Section 4.5.3.
  9. Spacers—materials and construction and drawings.
  10. Grilles—materials, placement and pattern, and drawings.

11. Detailed description of the framing, stile or rail, frame and sash corner/joint construction, glazing installation, weatherstripping (types and locations), drainage and finish.
12. All hardware—operator and other components.
13. All descriptive items in the simulation/test report which have not been measured or verified by the simulation/test lab shall be clearly indicated in the report.
14. The simulation/test specimen size and design.
  - (i) For test, all the information required by Appendix D: Test Data Sheets (Required Information).
  - (j) For test, date of last complete hot box calibration and last calibration check.
  - (k) For test, statement of experimental uncertainty associated with tests and data reduction when available.
  - (l) Any additional comments or data deemed important in the understanding or review of the report.
  - (m) Name and signature of individual accepting responsibility for the technical accuracy of a simulation/test report.
  - (n) Name and signature of individual conducting the simulation/test.
  - (o) A statement that the report may not be reproduced, except in full, without the approval of the laboratory.
  - (p) A statement that the report relates only to the fenestration products simulated/tested.
  - (q) For test, a drawing indicating the location of each specified thermocouple and the corresponding surface temperature.
  - (r) A statement indicating whether the product simulated/tested was a production line specimen, a prototype specimen, or as a test only option as identified by the manufacturer.
  - (s) All numerical values derived from the simulation/test of the product, except where otherwise indicated, shall be reported in the final report to two decimal places in accordance with ASTM E29 procedures. (i.e. X.XX).
  - (t) Any non-standard simulation/test specimen size and non-standard simulation/test conditions used shall also be reported. If the simulation/test specimen size is non-standard ( $\pm 13$  mm) width and/or height of the Model size referenced in Table 1, then the text "non-standard size" shall be inserted immediately following the size everywhere the size is listed, both in the full report and in any summary. If the simulation/test conditions are non-standard, then the text "non-standard conditions" shall be inserted immediately following the name of the procedure everywhere the simulation/test procedure is listed, both in the full report and in any summary.

- (u) For test, the criteria used to establish steady-state conditions and the test period duration.
- (v) For test, the information as required in Appendix D: Test Data Sheets (Required Information).
- (w) For test, the information required in the applicable procedure (e.g. for U-factor: Section 9 in ASTM C 1199, Section 12 in ASTM C 1363, and Section 12 in ASTM E 1423; for SHGC: Section 9 in NFRC 201; for visible transmittance: Section 10 in ASTM C 1175; for condensation, ??<sup>9</sup>.)

**4.6.2 Units.** Indices shall be reported in SI units. If both SI and I-P units are desired, indices shall be reported in SI (metric) units first, with I-P (inch-pound) units following in parentheses.

- (a) For U-factor, indices shall be reported to the nearest 0.05 W/m<sup>2</sup> K. (If I-P units are provided, U-factor shall be reported to the nearest 0.01 Btu/ft<sup>2</sup> F).
- (b) For Solar Heat Gain Coefficient, indices shall be reported to the nearest 0.01 with a leading figure.
- (c) For visible transmittance, indices shall be reported to the nearest 0.01 with a leading figure.
- (d) For condensation, indices shall be reported to the nearest whole number.

Calculations shall be done with a minimum of one additional decimal place beyond that specified above for reporting.

It is allowable to make measurements and inputs in I-P units, and to calculate results in I-P units and then to convert final answer to SI units.

---

<sup>9</sup> Need a section reference for simulation/testing?

## 5. SIMULATION

**5.1 General.** Simulation shall comply with the requirements of

- (a) 5.1 General, and
- (b) 5.2 U-factor (where simulation is being done for U-factor),
- (c) 5.3 Solar Heat Gain Coefficient (where simulation is being done for SHGC),
- (d) 5.4 Visible Transmittance (where simulation is being done for visible transmittance), and
- (e) 5.5 Condensation (where simulation is being done for condensation).

Simulations shall be performed using computer programs that comply with the ISO 15099 calculation procedure, except where noted.

**EXCEPTION:** For tubular daylighting devices, follow the procedures in Appendix E: Tubular Daylighting Devices.

### 5.2 U-factor.

**5.2.1 General Equation.** The total product U-factor shall be determined using computed U-factors for the center-of-glazing area, edge-of-glazing area, frame area, divider area, and divider-edge area obtained by methods defined in ISO 15099, and the following equation:

$$U_t = \left( \frac{\Sigma(U_c \times A_c) + \Sigma(U_e \times A_e) + \Sigma(U_f \times A_f) + \Sigma(U_d \times A_d) + \Sigma(U_{de} \times A_{de})}{A_{pf}} \right)$$

where

$U_t$  = U-factor of the total product, W/(m<sup>2</sup>•K)

$U_c$  = center-of-glazing U-factor, W/(m<sup>2</sup>•K)

$U_d$  = divider U-factor, W/(m<sup>2</sup>•K)

$U_{de}$  = divider-edge U-factor, W/(m<sup>2</sup>•K)

$U_e$  = edge-of-glazing U-factor, W/(m<sup>2</sup>•K)

$U_f$  = frame U-factor, W/(m<sup>2</sup>•K)

$A_c$  = center-of-glazing area, m<sup>2</sup>

$A_d$  = divider area, m<sup>2</sup>

$A_{de}$  = divider-edge area, m<sup>2</sup>

$A_e$  = edge-of-glazing area, m<sup>2</sup>

$A_f$  = frame area, m<sup>2</sup>

$A_{pf}$  = projected fenestration area, m<sup>2</sup>

### 5.2.2 Environmental Conditions.

**5.2.2.1 Temperatures.** The temperature conditions used in the simulations shall be: exterior air and sky temperatures of -18 °C, and an interior temperature of 21 °C.

**5.2.2.2 Surface Conductances.** Surface conductance values used in the simulations shall be in accordance with ISO 15099. For purposes of this standard, the outdoor side heat transfer surface conductance for convection shall be  $24 \text{ W/m}^2\cdot\text{K}$  (which corresponds to a wind speed of approximately 5.0 m/s).

**5.2.2.3 Radiation.** Radiation heat transfer shall be simulated in accordance with ISO 15099. ISO 15099 has two methods for handling detailed radiation heat transfer on interior surfaces of projecting products. Per ISO 15099 either of these methods is acceptable.

**5.2.2.4 Solar Radiation.** The incident solar radiation used in the simulations shall be  $0 \text{ W/m}^2$ .

### **5.2.3 Computations.**

**5.2.3.1 Center-of-Glazing.** Center-of-glazing U-factor shall be computed using procedures in compliance with ISO 15099.

**EXCEPTION:** For products where the center-of-glazing component can not be simulated, the center-of-glazing component only (without any frame) shall be tested in accordance with:

(a) homogeneous materials

*ASTM C 177 Test Method for Steady-State Heat Flux Measurements and Thermal Transmission Properties by Means of the Guarded Hot Plate Apparatus.*

*ASTM C 518 Test Method for Steady-State Thermal Heat Flux Measurements and Transmission Properties by Means of the Heat Flow Meter.*

(b) non-homogeneous materials

*ASTM C 1199 Standard Test Method for Measuring the Steady-State Thermal Transmittance of Fenestration Systems Using Hot Box Methods.*

These results shall be used in the simulation.

**5.2.3.2 Edge-of-Glazing, Frame, Divider, and Divider-Edge.** Using a computer program capable of modeling two-dimensional heat transfer, and procedures in compliance with ISO 15099, the following shall be computed:

(a) the edge-of-glazing U-factor;

(b) the frame U-factor;

(c) the divider U-factor; and

(d) the divider-edge U-factor.

### **5.3 Solar Heat Gain Coefficient (SHGC)**

**5.3.1 General Equation.** The total product SHGC shall be determined using computed SHGCs for the glazing area and for the frame and divider area obtained by methods defined in ISO 15099 and using the following equation:

$$\text{SHGC}_t = \left( \frac{\Sigma(\text{SHGC}_c \times A_c) + \Sigma(\text{SHGC}_e \times A_e) + \Sigma(\text{SHGC}_f \times A_f) + \Sigma(\text{SHGC}_d \times A_d) + \Sigma(\text{SHGC}_{de} \times A_{de})}{A_{pf}} \right)$$

where

$\text{SHGC}_t$  = solar heat gain coefficient of the total product, dimensionless

$\text{SHGC}_c$  = solar heat gain coefficient of the center-of-glazing, dimensionless

$\text{SHGC}_e$  = solar heat gain coefficient of the edge-of-glazing, dimensionless

$\text{SHGC}_f$  = solar heat gain coefficient of the frame, dimensionless

$\text{SHGC}_d$  = solar heat gain coefficient of the divider, dimensionless

$\text{SHGC}_{de}$  = solar heat gain coefficient of the divider-edge, dimensionless

$A_c$  = center-of-glazing area,  $\text{m}^2$

$A_e$  = edge-of-glazing glass area,  $\text{m}^2$

$A_f$  = frame area,  $\text{m}^2$

$A_d$  = divider area,  $\text{m}^2$

$A_{de}$  = divider-edge area,  $\text{m}^2$

$A_{pf}$  = projected fenestration area,  $\text{m}^2$

For greenhouse/garden windows, calculate the solar heat gain perpendicular to the rough opening in the wall. Note that this requires an off-angle calculation for sloped panels. Do not include diffuse solar gain through side panels.

### 5.3.2 Environmental Conditions.

**5.3.2.1 Temperatures.** The temperature conditions used in the simulations shall be: outdoor air and sky temperatures of 32 °C, and an indoor temperature of 24 °C.

**5.3.2.2 Surface Conductances.** Surface conductance values used in the simulations shall be in accordance with ISO 15099. For purposes of this standard, the outdoor side heat surface conductance for convection shall be 12  $\text{W}/\text{m}^2\text{K}$  (which corresponds to a wind speed of approximately 2.5 m/s).

**5.3.2.3 Radiation.** Radiation heat transfer shall be simulated in accordance with ISO 15099. ISO 15099 has two methods for handling detailed radiation heat transfer on interior surfaces of projecting products. Per ISO 15099 either of these methods is acceptable.

**5.3.2.4 Solar Radiation.** The incident solar radiation used in the simulations shall be 783  $\text{W}/\text{m}^2$ .

### 5.3.3 Computations.

**5.3.3.1 Center-of-Glazing.** The center-of-glazing SHGC shall be computed using procedures in compliance with ISO 15099.

**EXCEPTION:** For products where the center-of-glass component can not be simulated, the center-of-glazing component only (without any frame) shall be tested in accordance with NFRC 201 *Interim Standard Test Method for*

*Measuring the Solar Heat Gain Coefficient of Fenestration Systems Using  
Calorimetry Hot Box Methods.* These results shall be used in the simulation.

**5.3.3.2 Edge-of-Glazing and Divider-Edge.** The edge-of-glazing and divider-edge SHGC shall be equal to the center-of-glazing SHGC.

**5.3.3.3 Frame and Divider.** The frame and divider SHGC shall be computed using a procedures in compliance with ISO 15099. ISO 15099 has two methods for handling solar heat gain on the frame and divider. Per ISO 15099 either of these methods is acceptable.

A frame and divider absorptance of 0.3 shall be used for all products except glazed wall and sloped glazing systems. Glazed wall and sloped glazing systems shall use a frame and divider absorptance of 0.5.

**5.3.3.4 Matrix.** Determine the total fenestration product SHGC values for center-of-glazing SHGC values of 0.0 and 1.0. Total fenestration product SHGC values should be determined for all applicable cases. Where grouping is done for dividers in accordance with Section 0: calculate for the cases with no dividers, and all the cases identified in Section 0.

For any known center-of-glazing SHGC, the total fenestration product SHGC is to be calculated using the following equation:

$$SHGC_w = SHGC_0 + SHGC_{cg} * (SHGC_1 - SHGC_0)$$

where

SHGC<sub>0</sub> = the total fenestration product SHGC for the center-of glass SHGC of 0.0 and

SHGC<sub>1</sub> = the total fenestration product SHGC for the center-of-glazing SHGC of 1.0.

Calculations with SHGC<sub>c</sub>, SHGC<sub>0</sub>, and SHGC<sub>1</sub> values shall be done with a minimum of one additional decimal place beyond that specified for reporting in Section 0. The final SHGC value shall be reported in accordance with Section 0.

## **5.4 Visible Transmittance (VT)**

**5.4.1 General Equation.** The total product VT shall be determined using computed VTs for the glazing area and for the frame and divider area obtained by methods defined in ISO 15099 and using the following equation:

$$VT_t = \left( \frac{\Sigma(VT_c \times A_c) + \Sigma(VT_e \times A_e) + \Sigma(VT_f \times A_f) + \Sigma(VT_d \times A_d) + \Sigma(VT_{de} \times A_{de})}{A_{pf}} \right)$$

where

$VT_t$  = visible transmittance of the total product, dimensionless  
 $VT_c$  = visible transmittance of the center-of-glazing, dimensionless  
 $VT_e$  = visible transmittance of the edge-of-glazing, dimensionless  
 $VT_f$  = visible transmittance of the frame, dimensionless  
 $VT_d$  = visible transmittance of the divider, dimensionless  
 $VT_{de}$  = visible transmittance of the divider-edge, dimensionless  
 $A_c$  = center-of-glazing area,  $m^2$   
 $A_e$  = edge-of-glazing area,  $m^2$   
 $A_f$  = frame area,  $m^2$   
 $A_d$  = divider area,  $m^2$   
 $A_{de}$  = divider-edge area,  $m^2$   
 $A_{pf}$  = projected fenestration area,  $m^2$

For greenhouse/garden windows, calculate the visible light perpendicular to the rough opening in the wall. Note that this requires an off-angle calculation for sloped panels. Do not include visible light through side panels.

**5.4.2 Environmental Conditions.** The environmental conditions used in the simulations for visible transmittance shall be the same as those used for SHGC calculations in Section 0.

**5.4.3 Computations.**

**5.4.3.1 Center-of-Glazing.** The center-of-glazing VT shall be computed using procedures in compliance with ISO 15099.

**EXCEPTION:** For products where the center-of-glazing component can not be simulated, the center-of-glazing shall be tested in accordance with ASTM C1175 “Standard Test Method for Determining Solar or Photopic Reflectance, Transmittance, and Absorptance of Materials Using a Large Diameter Integrating Sphere”. These results shall be used in the simulation.

**5.4.3.2 Edge-of-Glazing and Divider-Edge.** The edge-of-glazing and divider-edge SHGC shall be equal to the center-of-glazing SHGC.

**5.4.3.3 Frame and Divider.** Opaque frame and opaque divider VT are equal to 0.00. Non-opaque frame and divider VT shall be determined in accordance with Section 5.4.3.1, Exception.

**5.4.3.4 Matrix.** Determine the total fenestration product VT values for center-of-glazing VT values of 0.0 and 1.0. Total fenestration product SHGC values should be determined for all applicable cases. Where grouping is done for dividers in accordance with Section 0: calculate for the cases with no dividers, and all the cases identified in Section 0.

For any known center-of-glazing VT, the total fenestration product VT is to be calculated using the following equation:

$$VT_w = VT_0 + VT_c * (VT_1 - VT_0)$$

where:

VT<sub>0</sub> = the total fenestration product VT for the center-of glass VT of 0.0 and

VT<sub>1</sub> = the total fenestration product VT for the center-of-glazing VT of 1.0.

Calculations with VT<sub>c</sub>, VT<sub>0</sub>, and VT<sub>1</sub> values shall be done with a minimum of one additional decimal place beyond that specified for reporting in Section 0. The final SHGC value shall be reported in accordance with Section 0.

## 5.5 Condensation

**\*\*\* Condensation Resistance is determined by NFRC using NFRC 500 and CSA determines condensation resistance using CSA A440-98. The Thermal Harmonization Task Force has had some difficulty trying to harmonize a procedure for condensation resistance simulation. Attached is a summary of the differences between the two simulation approaches to condensation resistance. Any comments on these issues would be greatly appreciated to help the Task Force come to a resolution.\*\*\***

### Condensation Simulation Comparison

Issues	CSA A440-98	NFRC 500
Restrictions on use.	Operator type use restriction. Air leakage limits. Frame material limits.	Simulate if you can simulate U-factor, otherwise test.
Boundary Conditions	Exterior: 30 W/m <sup>2</sup> C, -18°C  Interior: 21°C Convection: Natural convection with : 1/8, 3/8, 5/8, 7/8 reduction factors as the boundary approaches the sightline. Radiation: radiation heat transfer coefficient of the glass is applied to both the glass and the frame.	Exterior: 29 W/m <sup>2</sup> C, -18°C  Interior: 21°C Convection: Glass is natural convection based glass surface temperature. Frame is a fixed value based on the frame material type. Radiation: calculated based on a gray body enclosure model.
Temperature data points used in calculations	Glass: Temperature at a point 10mm from the sightline of the frame on the sill section model only.  Frame: Coldest temperature on the sill section frame no closer than 10mm to the sight line.	Center-of-Glass: Center-of-glass temperature if below a given dew point temperature  Edge-of-Glass: Any calculated dew-point temperature on the edge-of-glass below a given dew-point temperature

		<p>Frame:</p> <p>Any calculated dew-point temperature on the frame below a given dew-point temperature</p>
Index Calculation	<p>Glass:</p> <p>Ratio of the difference between the calculated glass surface temperature at 10mm and the exterior air temperature, and the difference between the interior and exterior air temperatures</p> <p>Frame:</p> <p>Ratio of the difference between the calculated coldest frame surface temperature and the exterior air temperature, and the difference between the interior and exterior air temperatures</p>	<p>Center-of-Glass:</p> <p>Detailed weighted calculation based on three relative humidity levels including all center-of-glass temperatures below the dew-point temperature at each relative humidity</p> <p>Edge-of-Glass:</p> <p>Detailed weighted calculation based on three relative humidity levels including all edge-of-glass temperatures below the dew-point temperature at each relative humidity</p> <p>Frame:</p> <p>Detailed weighted calculation based on three relative humidity levels including all frame temperatures below the dew-point temperature at each relative humidity</p>
Computer tools used	Vision4 and Frame4	Window 4.1 and Therm 2.1
Final Index Value	Lower of glass & frame.	Lower of glass, edge-of-glass & frame.

## **6. TESTING**

**6.1 General.** Testing shall comply with the requirements of

- (a) 6.1 General, and
- (b) 6.2 U-factor (where testing is being done for U-factor),
- (c) 6.3 Solar Heat Gain Coefficient (where testing is being done for SHGC),
- (d) 6.4 Visible Transmittance (where testing is being done for visible transmittance),  
and
- (e) 6.5 Condensation (where testing is being done for condensation).

**EXCEPTION:** For tubular daylighting devices, follow the procedures in Appendix E: Tubular Daylighting Devices.

**6.2 U-factor.** The total fenestration product U-factor shall be determined in accordance with the following standards and test conditions:

- (a) ASTM C 1199 *Standard Test Method for Measuring the Steady-State Thermal Transmittance of Fenestration Systems Using Hot Box Methods*, and
- (b) ASTM E 1423 *Standard Practice for Determining the Steady State Thermal Transmittance of Fenestration Systems*.
- (c) Test conditions:
  - (1) Interior ambient temperature of 21 °C ( $\pm 0.25$  °C).
  - (2) Exterior ambient temperature of -18 °C ( $\pm 0.25$  °C).
  - (3) The interior relative humidity shall be maintained at or below 15%.
  - (4) An interior measured film coefficient during CTS (calibration transfer standard) panel calibration testing of 8 W/m<sup>2</sup> °C ( $\pm 5\%$ ).
  - (5) An exterior measured film coefficient during CTS panel calibration testing of 29 W/m<sup>2</sup> °C ( $\pm 10\%$ ).

**6.3 Solar Heat Gain Coefficient (SHGC).** The total fenestration product SHGC shall be determined in accordance with the following NFRC 201 *Standard Test Method for Measuring the Solar Heat Gain Coefficient of Fenestration Systems Using Calorimetry Hot Box Methods*.

**6.4 Visible Transmittance (VT).** The non-opaque components (e.g. center-of-glazing) shall be tested in accordance with ASTM C 1175 “Standard Test Method for Determining Solar or Photopic Reflectance, Transmittance, and Absorptance of Materials Using a Large Diameter Integrating Sphere”. The opaque components shall be assumed to have a visible transmittance of 0.0. An area-weighted average calculation shall then be performed.

**6.5 Condensation.** The condensation resistance index shall be determined using the procedures in 6.2, tested concurrently when testing for U-factor, and under the same

environmental test conditions. Additional thermocouples shall be installed as indicated in Figure 5: Thermocouple Placement.<sup>10</sup>

---

<sup>10</sup> Final thermocouple placement to be determined.

## **FIGURES**

**Figure 1: Window Cross-section<sup>11</sup>**

---

<sup>11</sup> Jeff to provide window figure, convert to SI.

**Figure 2: Door Cross-section<sup>12</sup>**

---

<sup>12</sup> Jeff to provide door figure, convert to SI.

**Figure 3: Factory Assembled Composite Window Units**

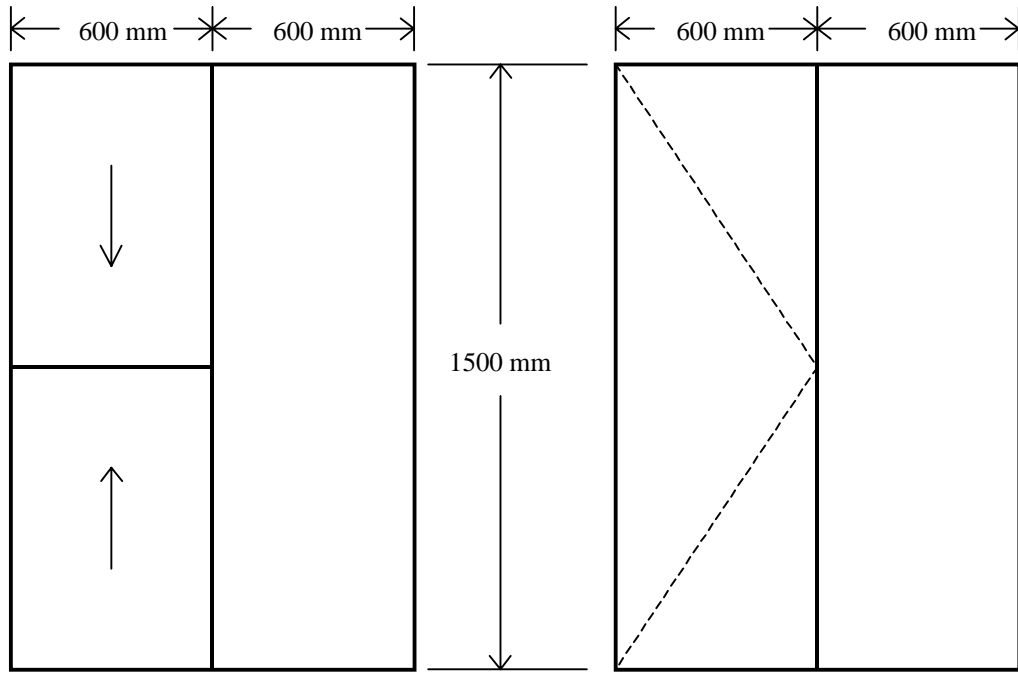

Sliding beside fixed

Side-hinged beside fixed

**Fixed Beside Sliding or Side-hinged**

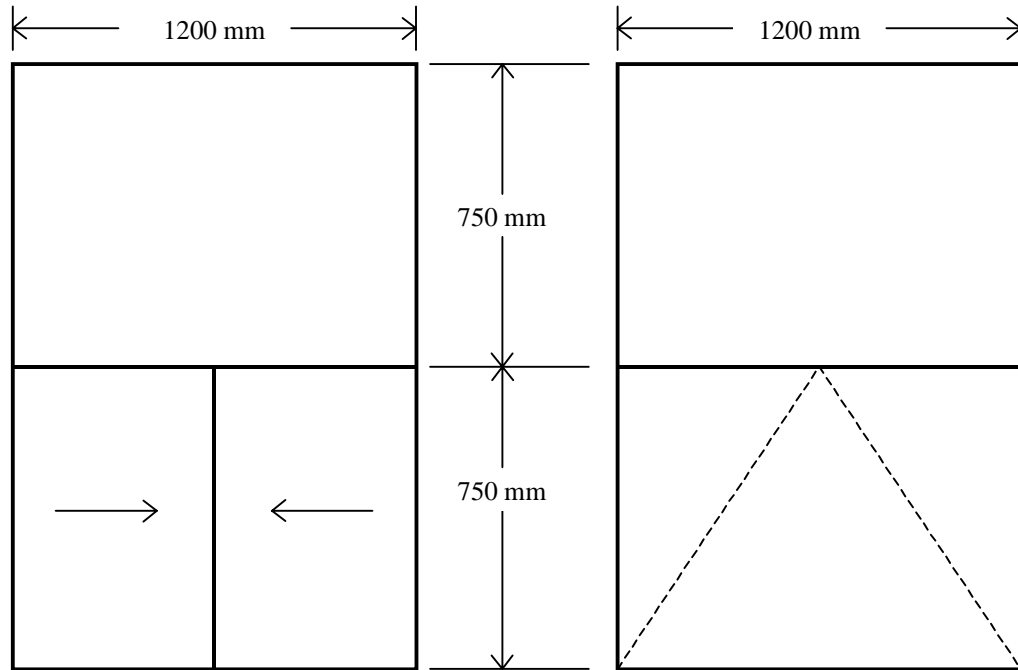

Fixed over Sliding

Fixed over Top-hinged

**Fixed over/under Sliding or Top/Bottom-hinged**

**Figure 4: Divider Height and Divider Width**

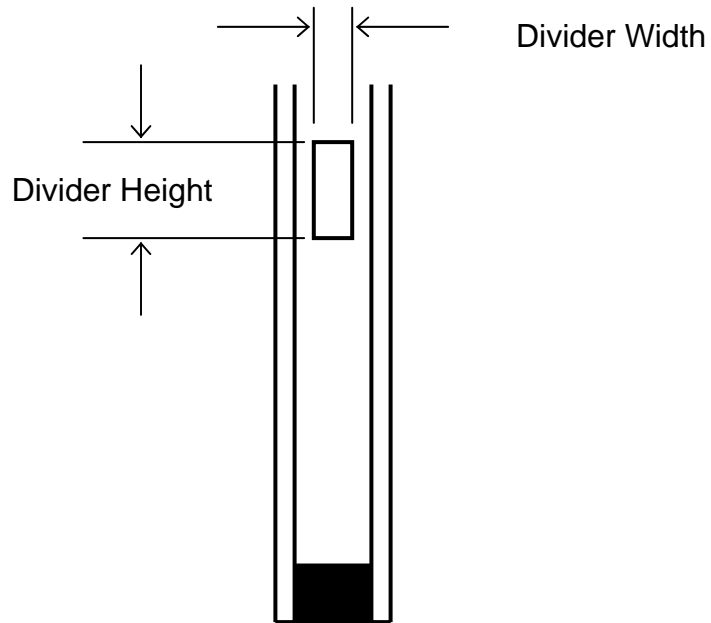

**Figure 5: Thermocouple Placement**

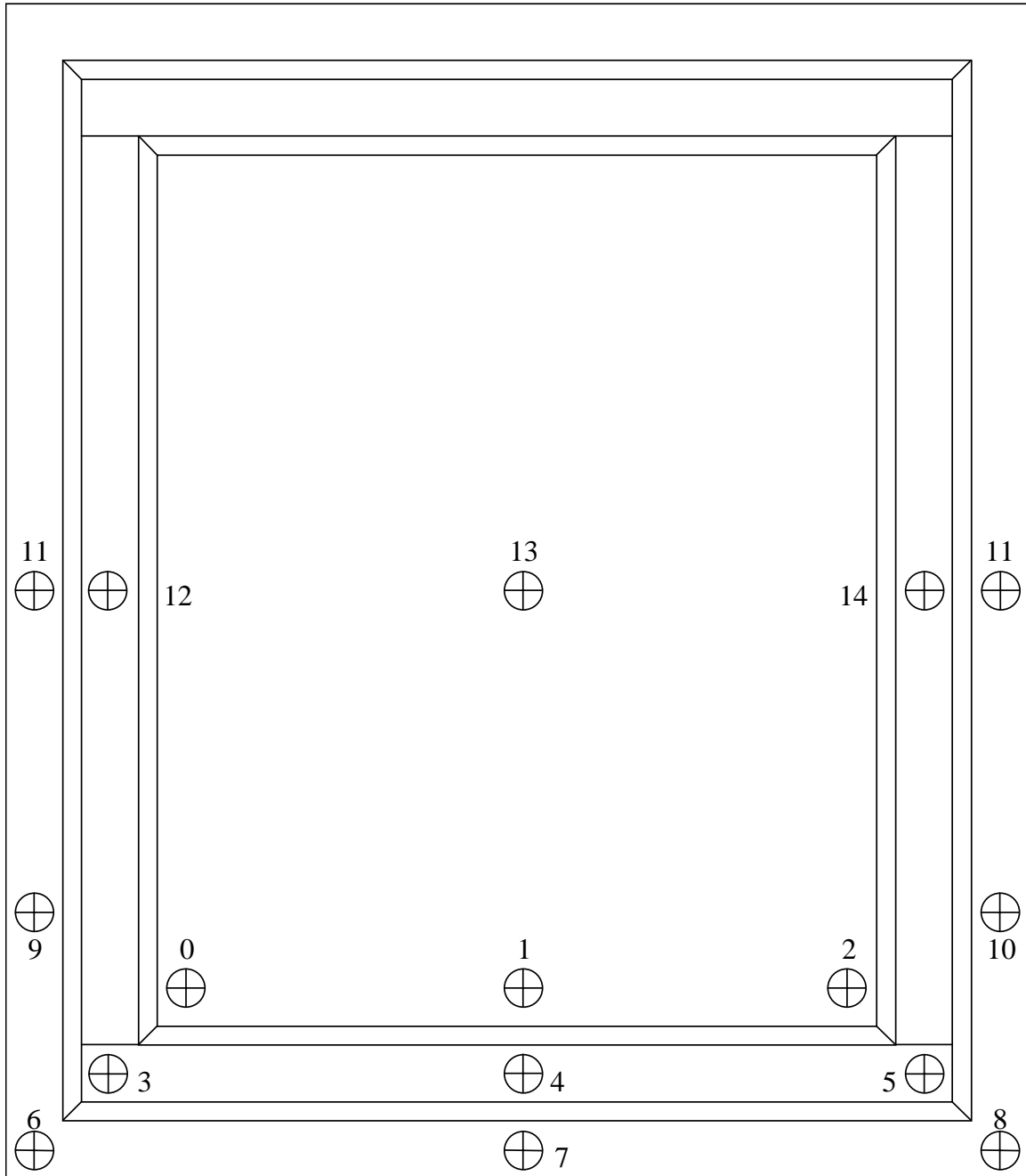

**Thermocouple Locations for Condensation Resistance Test  
For Fixed Windows**

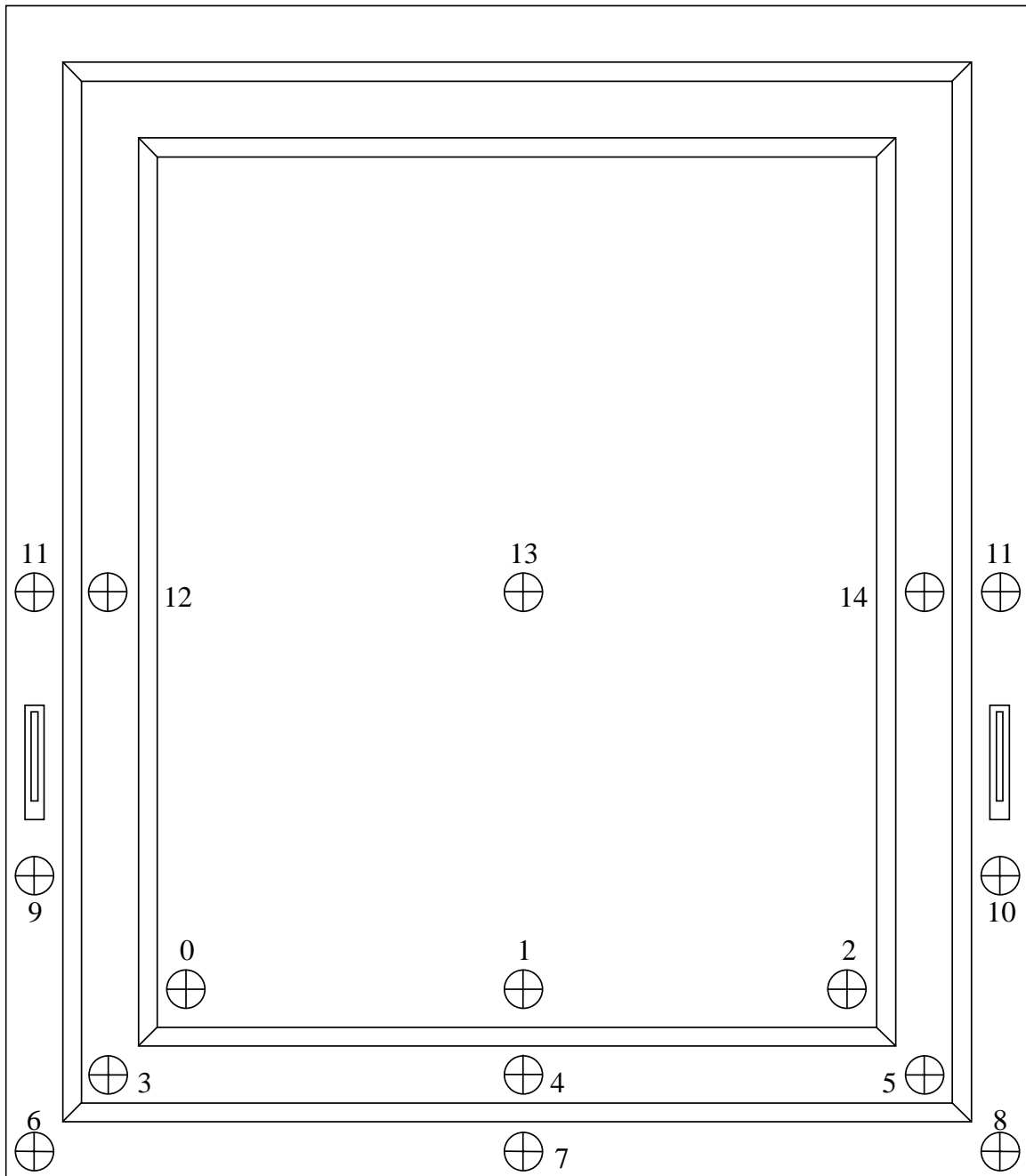
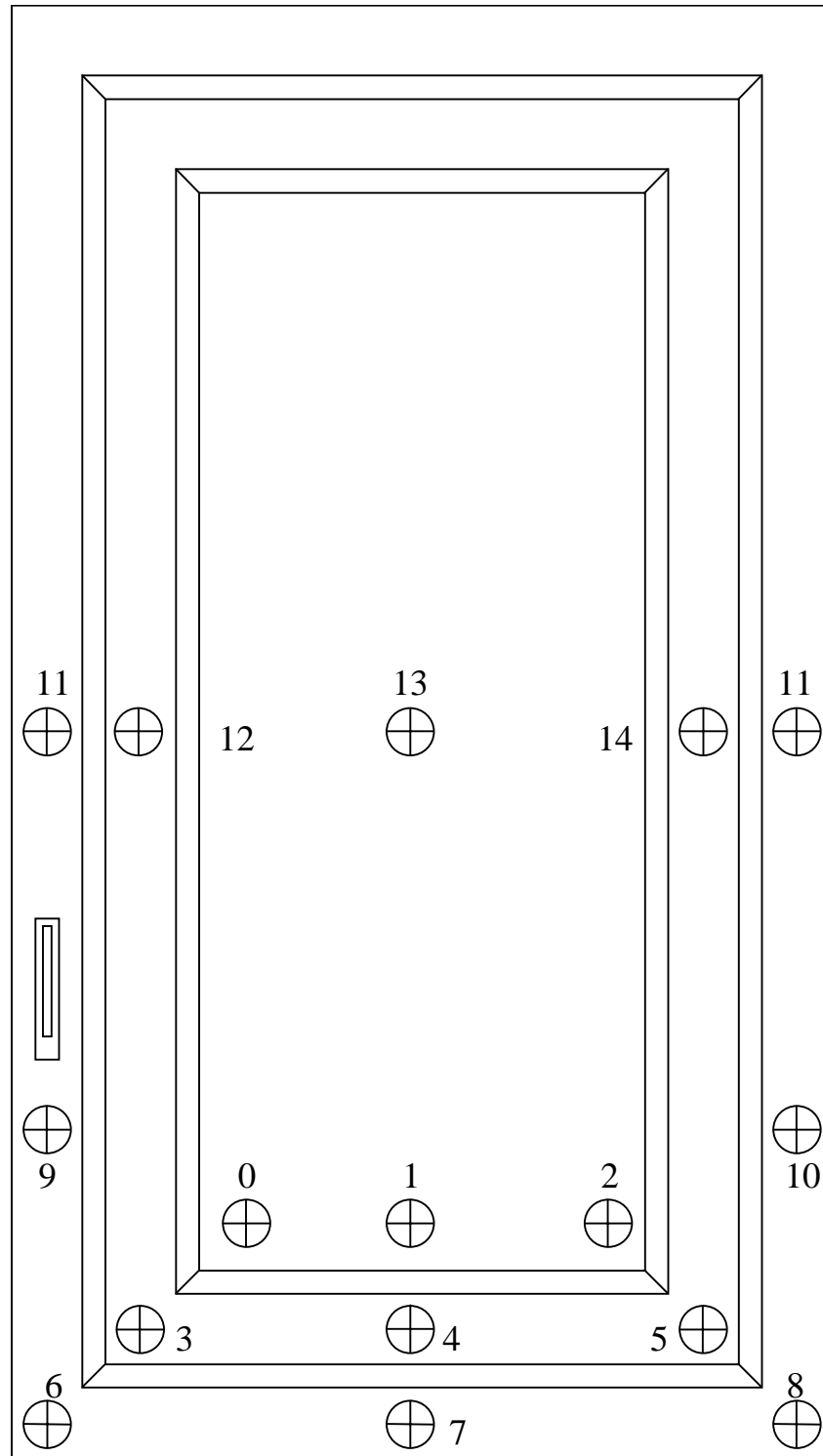

Figure C2  
Thermocouple Locations for Condensation Resistance Test  
For Awning Windows



**Figure C1**  
**Thermocouple Locations for Condensation Resistance Test**  
**For Casement Windows**

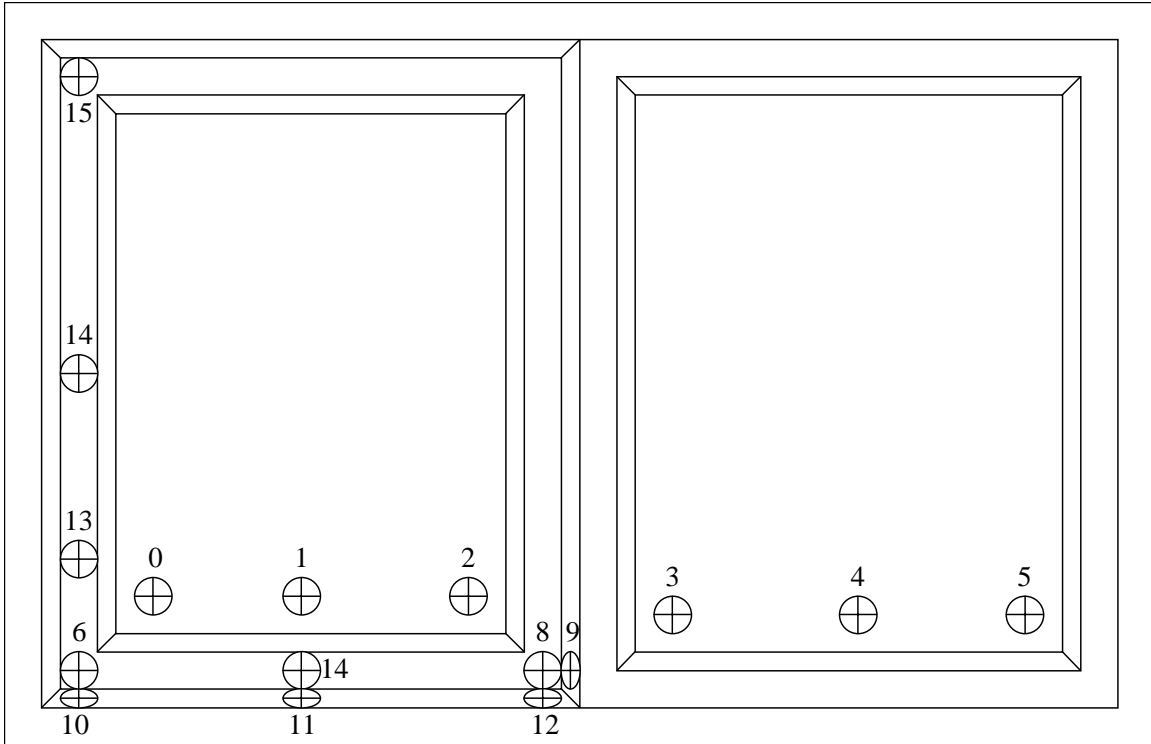
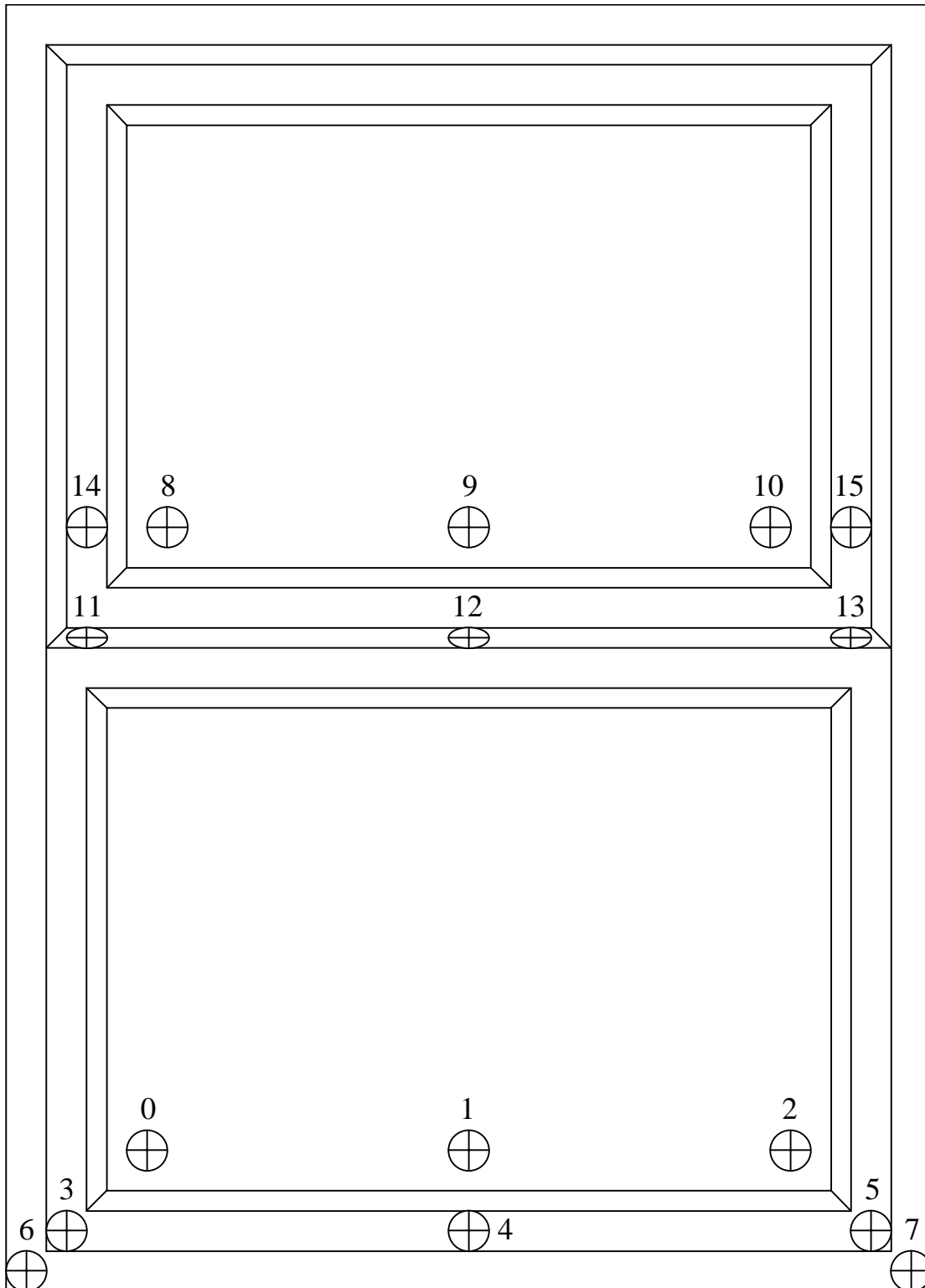

Figure C5  
Thermocouple Locations for Condensation Resistance Test  
For Horizontally Sliding Windows



**Figure C4**  
**Thermocouple Locations for Condensation Resistance Test**  
**For Vertically Sliding Windows**

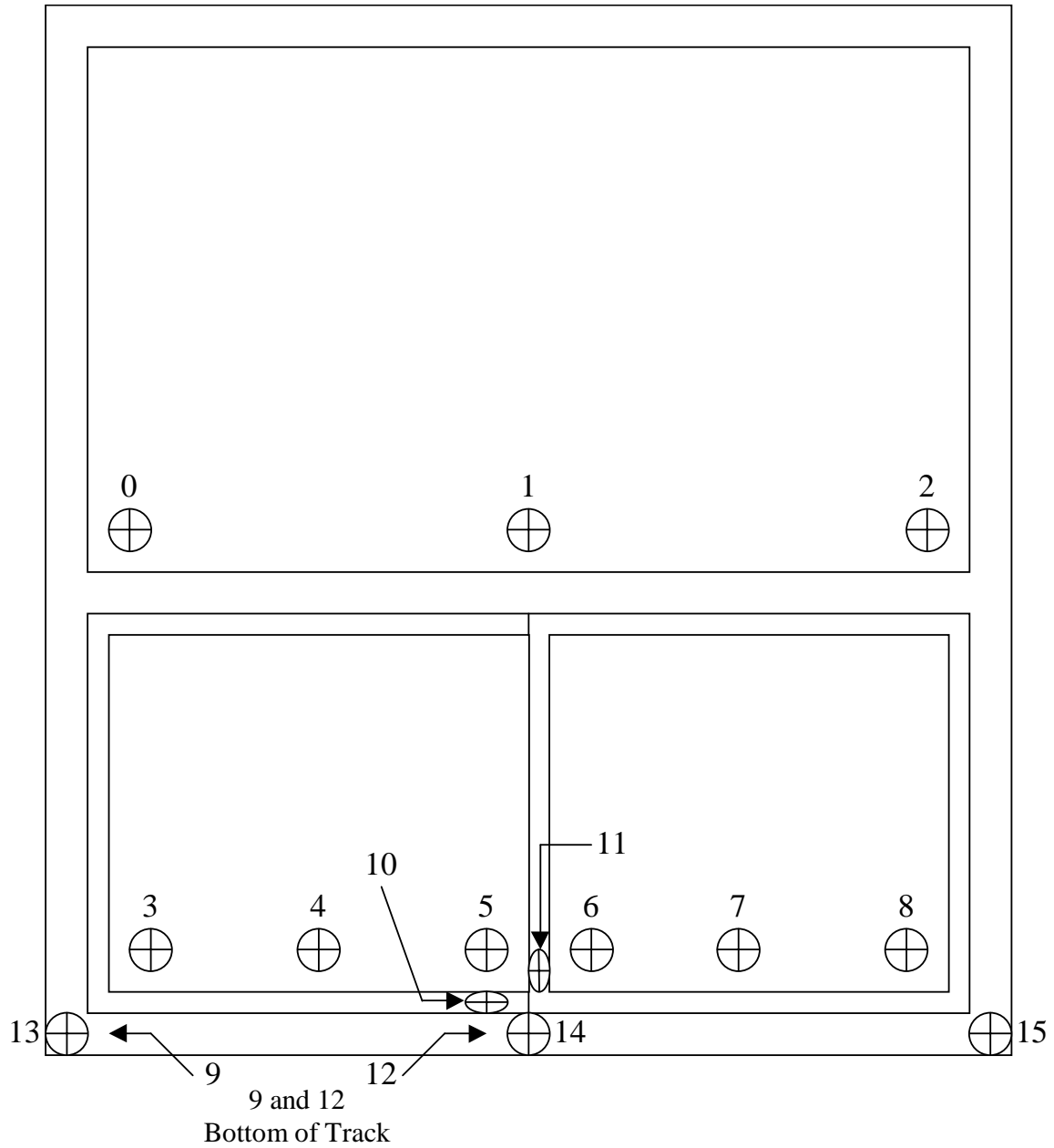
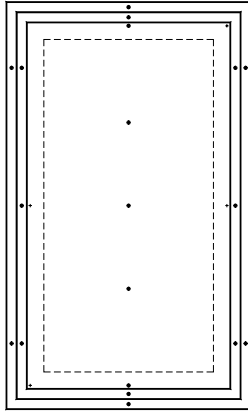
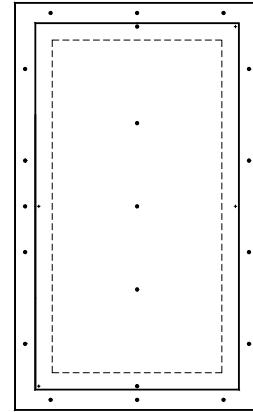

Figure C6  
Thermocouple Locations for Condensation Resistance Test  
For Composite Windows (Fixed over Sliding)



Casement and Projected Window  
Or Single Door with Frame



Fixed Window

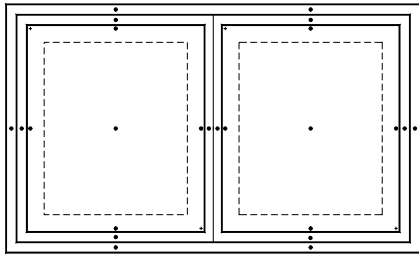

Horizontal Slider or  
Double Door with Frame

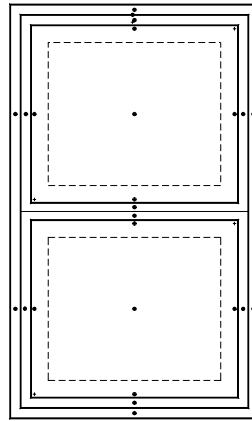

Vertical Slider

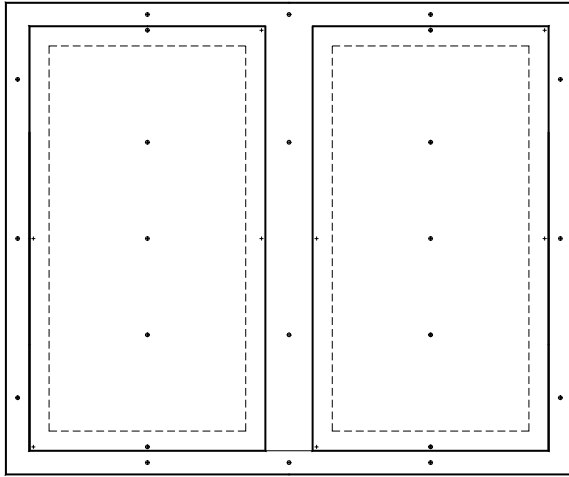

Glazed Wall Section



## APPENDICES

### Appendix A: Approximate I-P Conversions for Information Purposes Only

The units used throughout the document are SI (metric) units. All measurements are to be done in SI units. Compliance is to be determined based on SI units. The following are approximate I-P conversions for the SI units used in this procedure. **These conversions are for information only. They are NOT acceptable for determining compliance with this procedure.**

#### Approximate I-P Conversions for Information Purposes Only

	Exact SI Unit	Approximate I-P Conversion
<b>Section 2</b>		
Product size	700 mm	27 in.
<b>Section 4</b>		
Physically measured parameters	1 mm	0.04 in.
Glass thickness	2.5 mm	3/32 in.
Glass thickness	3.0 mm	1/8 in.
Glass thickness	4.0 mm	5/32 in.
Glass thickness	5.0 mm	3/16 in.
Glass thickness	6.0 mm	1/4 in.
Glass thickness	8.0 mm	5/16 in.
Glazing deflection	3 mm	1/8 in.
Glazing deflection	6 mm	1/4 in.
Gap width	13 mm	1/2 in.
Non-standard size width and/or height	13 mm	1/2 in.

	<b>Exact SI Unit</b>	<b>Approximate I-P Conversion</b>
Divider size	20 mm	3/4 in.
Divider size	25 mm	1 in.
Divider size	40 mm	1-1/2 in.
Outdoor air ventilator assembly	50 mm	2 in.
Product size	300 mm	12 in.
Product size	600 mm	24 in.
Product size	700 mm	27 in.
Product size	1000 mm	40 in.
Product size	1180 mm	46-1/2 in.
Product size	1200 mm	48 in.
Product size	1500 mm	60 in.
Product size	2000 mm	80 in.
Product size	3000 mm	120 in.
Default door frames	1.4 mm	0.055 in.
Default door frames	1.6 mm	0.065 in.
Default door frames	3 mm	1/8 in.
Default door frames	20 mm	3/4 in.
Default door frames	115 mm	4-9/16 in.
Default door frames	120 mm	4-3/4 in.
Default door frames	145 mm	5-3/4 in.
Thermal break conductivity	0.52 W/m <sup>2</sup> •K <sup>13</sup>	3.6 Btu•in./h•ft <sup>2</sup> •°F
Physical measurement accuracy	1 mm	0.04 in.
U-factor	0.01 W/m <sup>2</sup> •K	0.002 Btu/h•ft <sup>2</sup> •°F
<b>Section 5</b>		
Outdoor side heat surface conductance for convection	12 W/m <sup>2</sup> •K	2.1 Btu/h•ft <sup>2</sup> •°F
Outdoor side heat surface conductance for convection	24 W/m <sup>2</sup> •K	4.2 Btu/h•ft <sup>2</sup> •°F
Incident solar radiation	783 W/m <sup>2</sup>	248 Btu/h•ft <sup>2</sup>
Temperature	-18 °C	0 °F

<sup>13</sup> Value to correspond with Appendix B.

	<b>Exact SI Unit</b>	<b>Approximate I-P Conversion</b>
Temperature	21 °C	70 °F
Temperature	24 °C	75 °F
Temperature	32 °C	90 °F
Wind speed	2.5 m/s	5.6 mph
Wind speed	5.0 m/s	11.2 mph
<b>Section 6</b>		
Outdoor side heat surface conductance for convection	8 W/m <sup>2</sup> •K	1.4 Btu/h•ft <sup>2</sup> •°F
Outdoor side heat surface conductance for convection	29 W/m <sup>2</sup> •K	5.1 Btu/h•ft <sup>2</sup> •°F
Temperature	-18 °C	0 °F
Temperature	21 °C	70 °F
<b>Appendix E</b>		
Product size	13 mm	0.5 in.
Product size	250 mm	10 in.
Product size	350 mm	14 in.
Product size	750 mm	30 in.
Product size (area)	0.001 m <sup>2</sup>	0.01 ft <sup>2</sup>
Product size (area)	0.096 m <sup>2</sup>	1.04 ft <sup>2</sup>
Insulation R-value	5.3 m <sup>2</sup> •K/W	30 ft <sup>2</sup> °F/Btu

## Appendix B: Material Conductivities

\*\*\* Note this table is preliminary, data based on ISO 15099 and NFRC.  
Values to be finalized for later version. \*\*\*

Category	Name	Density (kg/m <sup>3</sup> )	k (W/m•K)	Source	Recommended value
<b>Rubber</b>					
	Butadiene	980	0.25	1	
	Butyl rubber, (isobutene), solid/hot melt	1200	0.24	1,3,4,6	
	Expanded rubber (rigid)	72	0.032	2	
	Ethylene propylene diene monomer(EPDM)	1150	0.25	1	
	Foam Rubber		0.03	11	
	Foam Rubber	60-80	0.06	1,6	0.06
	Hard rubber (ebonite), solid	1200	0.17	1	
	Natural rubber	910	0.13	1	
	Neoprene(polychloroprene)		0.19	11	
	Neoprene(polychloroprene)	1240	0.23	1,10	0.23
	Polyisobutylene (PIB)	930	0.2	1	
	Polyisobutylene (PIB)		0.24	4,6	0.24
	Polysulphide	1700	0.4	1	
	Polysulphide		0.19	4,6	0.4
	Rubber,Silicone	1048	0.16	10	
	Rubber,Sponge	77	0.039	10	
	Vulcanized rubber, hard		0.16	5,8	
	Vulcanized rubber, soft		0.1	5	
<b>Polymer</b>					
	Acrylic	1050	0.2	1,6	
	Acrylic	1188	0.179	10	0.2
	Cellular Urea-Formaldehyde	16	0.0328	10	
	Cellular Polystyrene, Expanded	13	0.0378	10	
	Cellular Polystyrene, Extruded	35	0.0306	10	
	Cellular Polyurethane	61	0.021	10	
	Elastomeric foam, flexible		0.05	1	
	Epoxy resin		0.2	1,6	
	Fiber glass(PE resin)		0.3	4,6	
	Fiber glass(reinforced nylon)		0.231	11	
	Phenolic resin		0.3	1	
	Poly(methyl)Methacrylate	1175	0.16	10	
	Polyacetate		0.3	1	
	Polyamide 6.6 with 25% glass fibre		0.3	1	
	Polyamide(nylon)		0.25	1,4,6	

Category	Name	Density (kg/m <sup>3</sup> )	k (W/m•K)	Source	Recommended value
	Polycarbonate		0.23	6	
	Polycarbonate	1200	0.2	1	
	Polycarbonate		0.19	11	0.23
	Polyester	153	0.053	10	
	Polyester resin	1400	0.19	1	
	Polyester resin		0.3	6	0.3
	Polyethylene foam		0.05	1	
	Polyethylene/polythene HD,high density	980	0.5	1,11	
	Polyethylene/polythene LD,low density	920	0.33	1,11	
	Polymethylmethacrylate(PMMA)		0.18	1	
	Polypropylene		0.22	1	
	Polypropylene with 25% glass fibre		0.25	1	
	Polystyrene	1050	0.16	1	
	Polystyrene		0.17	6	
	Polystyrene		0.037	11	0.17
	Polystyrene-expanded type1		0.037	11	
	Polystyrene-expanded type2&3		0.035	11	
	Polystyrene-extruded type 2,3&4		0.029	11	
	Polytetrafluoroethylene(PTFE)		0.256	10	
	Polyurethane	1390	0.25	1	0.25
	Polyurethane foam	70	0.05	1	0.05
	Polyurethane foam		0.03	4	0.03
	Polyurethane foam	24-40	0.023- 0.026	2	0.026
	Polyurethane foam, with CO2	27-114	0.0291	1	
	Polyurethane foam insulation (spray applied)		0.025	11	
	Polyurethane, HCFC blown-5 yr. aged		0.022	11	
	Polyurethane, HCFC blown-initial		0.017	11	
	Polyvinylchloride(PVC) flexible, with 40% softener		0.14	1	
	PVC/Vinyl (rigid)		0.17	4,6	
	Silicone		0.36	4	
	Silicone foam		0.168	14	
	Silicone foam		0.17	11	0.17
	Silicone, filled		0.5	1	
	Silicone, pure		0.35	1,6	
	Urethane (liquid)		0.31	4,6,11	
	Urethane		0.121	13	
	Urethane/polyurethane		0.21	1	0.31
	Vinyl (flexible)		0.12	6,11	
<b>Timber</b>					
	Balsa	117	0.048	7	

Category	Name	Density (kg/m <sup>3</sup> )	k (W/m•K)	Source	Recommended value
	Balsa	141	0.055	7,8	
	Balsa	320	0.084	7	
	Birch, yellow	689	0.144	7	
	California Redwood		0.107- 0.118	2	0.118
	Cedar		0.11	4,11	
	Cedar, western red	401	0.104	7	
	Cypress		0.097	8	
	Cypress,southern	465	0.120	7	
	Cypress,southern		0.13-0.132	2	0.132
	Douglas Fir	529	0.111	7	
	Douglas Fir-Larch		0.137- 0.145	2	0.145
	Elm (soft)	521	0.131	7	
	Elm, American		0.153	5	
	Fir		0.11	8	
	Fir		0.107-0.13	2	
	Fir		0.14	11	0.14
	Fir, white		0.12	5	
	Fir, white	401	0.094	7	0.120
	Hardwood		0.16	4,8,11	
	Hem-Fir		0.107-0.13	2	0.13
	Hemlock, eastern	457	0.115	7	
	Hemlock, western	457	0.109	7	
	Larch, western	625	0.143	7	
	Mahogany		0.13	5	
	Maple		0.157- 0.171	2	0.171
	Maple (hard)	713	0.167	7	
	Maple (soft)	625	0.150	7	
	Oak		0.16-0.18	2	0.18
	Oak, red	721	0.173	7	
	Oak, white	745	0.176	5,7	
	Pine		0.140	11	
	Pine		0.107-0.13	2	0.13
	Pine, longleaf	609	0.138	7	
	Pine, northern white	481	0.121	7	
	Pine, Norway	441	0.120	7	
	Pine, ponderosa	489	0.122	7	
	Pine, shortleaf	545	0.141	7	
	Pine, sugar	409	0.099	7	
	Pine, white		0.110	5	
	Redwood	417	0.109	4,7,11	0.109
	Softwood	400-600	0.140	6	
	Southern pine		0.144- 0.161	2	0.161
	Spruce		0.14	11	

Category	Name	Density (kg/m <sup>3</sup> )	k (W/m•K)	Source	Recommended value
	Spruce		0.107-0.13	2	0.14
	Spruce, Sitka	425	0.098	7	
	Studs: White Pine, Fir, Spruce		0.12	11	
	West Coast Woods, Cedars		0.098-0.13	2	
	Wood chip boarded		0.13	6	
	Yellow pine		0.15	8	
<b>Wood based panels</b>					
	Cement-bonded particleboard		0.23	1	
	Cement-bonded wood wool panels	500	0.1	1	
	Cement-bonded wood wool panels	700	0.14	1	
	Fibreboard,including MDF(medium density fibreboard,dry process)	250	0.07	1	
	Fibreboard,including MDF(medium density fibreboard,dry process)	400	0.1	1	
	Fibreboard,including MDF(medium density fibreboard,dry process)	600	0.14	1	
	Fibreboard,including MDF(medium density fibreboard,dry process)	800	0.18	1	
	Orited strand board(OSB)		0.13	1	
	Paricleboard	300	0.1	1	
	Paricleboard	600	0.14	1	
	Paricleboard	900	0.18	1	
	Plywood	300	0.09	1	
	Plywood	500	0.13	1	
	Plywood	700	0.17	1	
	Plywood	1000	0.24	1	
	Plywood	545	0.106	10	
	Plywood (softwood)		0.11	11	
	Plywood-Interior finish		0.12	11	
<b>Metals</b>					
	Aluminum	2700	220	6	237
	Alumium pure		237	8	
	Aluminum alloys	2800	160	1,4	
	Aluminum alloy 195 Cast (4.5Cu)		168	8	
	Aluminum alloy 2024 T6(4.5Cu,1.5Mg,0.6Mn)		177	8	
	Aluminum alloy 1100-O	2713	222	5,7	
	Aluminum alloy 3003-O	2713	163	7	
	Aluminum alloy 5056-O	2630	117	7	
	Aluminum alloy (96% Al,1.8% Cu,0.9% Fe,0.9% Cr,0.4% Si)		105	9	

Category	Name	Density (kg/m <sup>3</sup> )	k (W/m•K)	Source	Recommended value
	Aluminum Bronze(76% Cu,22% Zn,2% Al)		100	5	
	Aluminum Bronze(95% Cu,5% Al)		82.6	9	
	Steel	7800	50	1,6	
	Steel mild	7830	45.3	5	
	Steel(0.1% Carbon at 0C)		59	9	
	Steel(0.2% Carbon at 20C)		50	9	
	Steel(0.6% Carbon at 20C)		46.5	9	
	Steel-ANSI 304 stainless		14.3	11	
	Steel-ANSI 1040 mild		48	4,11	
	steel- galvanized sheet (0.14%C)		62	11	
	V 1 A steel		20.9	9	
	V 2 A steel		15.1	9	
	Stainless steel	7900	17	1,6	
<b>Glazing Materials</b>					
	Fiberglass		0.294		
	Flint(lead)		1.4	5	
	Glass (Plate or Float)		1	1,4,6	
	Glass mosaic		1.2	1,6	
	Jena 16 III		0.965	9	
	Mirror		0.802	9	
	Plexi		0.186	9	
	Plexiglass (perspex)		0.2	6	
	Plexiglass (PMMA) /Lucite		0.2	4	
	Pyrex		1	5	
	Quartz		1.4	1,6	
	Soda lime(plate)		1.4	8	
	Soda lime(crown)		1	1,5	1.4
			.		
<b>Insulating Materials</b>					
	Celluar phenolic(open cell)	29-35	0.033	2	
	Cellular glass	136	0.05	2	
	Cellular phenolic(closed cell)(CFC-11, CFC-113 exp.)	32	0.017	2	
	Cellular polyisocyanurate(gas-impermeable facers)	32	0.02	2	
	Cellular polyisocyanurate(gas-permeable facers)	24-40	0.023-0.026	2	0.026
	Cellular polyurethane/polyisocyanurate(CFC-11 exp.)(unfaced)	24	0.023-0.026	2	0.026
	Cellulose		0.039	10	

Category	Name	Density (kg/m <sup>3</sup> )	k (W/m•K)	Source	Recommended value
	Cellulose		0.057	5	
	Cellulose		0.04	11	0.057
	Cellulosic fiber		0.04	11	
	Cellulosic fiber	56-96	0.042- 0.049	2	0.049
	Cotton (fiber)		0.042	5	
	Expanded perlite, organic bonded	16	0.052	2	
	Expanded polystyrene(EPS)	10	0.0432	1	
	Expanded polystyrene(EPS)	15	0.0377	1	
	Expanded polystyrene(EPS)	20	0.035	1	
	Expanded polystyrene(EPS)	25	0.0336	1	
	Expanded polystyrene(EPS)	30	0.0327	1	
	Expanded polystyrene(EPS)	35	0.0321	1	
	Expanded polystyrene(EPS)	40	0.0317	1	
	Expanded polystyrene(EPS)	45	0.0315	1	
	Expanded polystyrene(EPS)	50	0.0314	1	
	Expanded polystyrene(EPS)	55	0.0313	1	
	Expanded polystyrene, molded beads	16	0.037	2	
	Expanded polystyrene, molded beads	24	0.035	2	
	Expanded polystyrene, molded beads	32	0.033	2	
	Expanded polystyrene,extruded(smooth skin surface)(HCFC-142b exp.)	29-56	0.029	2	
	Extruded polystyrene(XPS) CO2	31-51	0.034	1	
	Extruded polystyrene(XPS) foam with CFC	25-44	0.0292	1	
	Extruded polystyrene(XPS) with HCFC	21-68	0.0289	1	
	Felt		0.05	5	
	Glas fiber (semi-rigid) Sheathing		0.035	11	
	Glass fiber	56-72	0.038- 0.039	2	
	Glass fiber (rigid) Roof insulation		0.048	11	
	Glass fiber (spray applied)		0.039	11	
	Glass fiber ,organic bonded	64-140	0.036	2	
	Glass wool		0.038	5	
	Mineral fiber -high density (rock, slag, glass)		0.036	11	
	Mineral fiber with resin binder		0.042	2	
	Mineral fiber-loose fill (rock, slag, glass)		0.05	11	
	Mineral fiber-low density (rock, slag, glass)		0.042	11	
	Mineral fiber-med. density (rock, slag, glass)		0.039	11	

Category	Name	Density (kg/m <sup>3</sup> )	k (W/m•K)	Source	Recommended value
	Polyester fibre	15	0.0402	1	
	Polyester fibre	25	0.035	1	
	Polyester fibre	35	0.0332	1	
	Polyester fibre	45	0.0324	1	
	Polyisocyanurate/ployurethane-Unfaced Board		0.025	11	
	Polyisocyanurate/Polyurethane-Faced Sheathing		0.02	11	
	Polyisocyanurate/Polyurethane-Initial		0.017	11	
	Silica Aerogel		0.0284	10	
	straw		0.0556	10	
	Ureaformaldehyde foam	11--26	0.032-0.04	2	0.04
	Vermiculite		0.069	10	
<b>Miscellaneous</b>					
	Foam glass		0.04	1	
	Foam glass		0.04	12	0.04
	Mohair		0.14	4,11	
	Silica gel (desiccant)		0.13	1,4,6	
	Silica gel (desiccant)		0.03	11	
	Silicone Foam		0.12	4,6	
	Foam weather stripping		0.03	11	
<b>Source</b>					
1	prEn 12524: Building material and products-Hygrothermal properties-Tabulated design values , November 1999				
2	ASHRAE Fundamentals Handbook(SI), 1997				
3	Wright, J. L. and H. F. Sullivan (1989). "Thermal Resistance Measurement of Glazing System Edge-Seal and Seal Materials Using a Guarded Heater Plate Apparatus." At. 95-2.				
4	FRAME program material library-early version				
5	ASHRAE Handbook(SI), 1989				
6	CEN TC 89/WG 2: Tabulated Design Values of Thermal Conductivity(December 1992)				
7	D.F. Miner and J.B. Seastone, Handbook of Engineering Materials, 1955				
8	F.P. Incropera and D.P. Dewitt, Fundamental of Heat and Mass Transfer(Third edition), 1990				
9	Kuzman Raznjevic, Handbook of Thermodynamic Tables and Charts, McGraw-Hill Book Company				
10	NIST Heat Transmission Properties of Insulation and Building Materials Database				
11	FRAME program material library				
12	M. Loffler, Glazing Edge-Seal Using Foamglass as Spacer and Frameless Window Design, Solar Energy, Oct., 1997, pp303-312				
13	Fax from ORTECH International				
14	NRCC report, No. A3090.1, March 24, 1994				
*	The values from source 1 consist of values from different European countries				

### **Appendix C: Glazing Deflection**

Variations in the pressure in the space between the sheets of glazing in sealed glazing units may cause deflections in the glazing. In extreme cold weather cases, the glazing surfaces may bow and come into contact with each other at their centerpoints. This change in the enclosed space dimensions can significantly effect the thermal conductance and the thermal transmittance of the test specimen. Factors which can cause a pressure unbalance between the glazing unit enclosed air space and the surrounding environment are:

- (1) Differences in the barometric pressure due to a difference in the elevations of the fenestration system manufacturing facility and the testing facility.
- (2) Changes in barometric pressure at the testing facility due to local weather variations.
- (3) Changes in the mean temperature of the glazing unit enclosed airspace during testing.

Recognizing that glazing deflection can cause a change in the thermal conductance and the thermal transmittance an estimation of the gap spacing between the glazing sheets is required immediately before and after the test. The initial gap thickness can be estimated by either measuring the overall glazing thickness at the center or measuring the deflection profile of each glazing plate and then subtracting the thickness of the individual plates. Gap thickness during the test can be estimated from the initial thickness measurements minus the change in glazing deflections which occur during the test. The glazing deflection measurements shall be performed on both sides of the fenestration system and must be included in the test report. The glazing deflection measurements should be performed:

- (1) After the fenestration system has been delivered to the testing laboratory and has come to equilibrium in the laboratory.
- (2) Just before the test commences, and
- (3) Immediately after the test is completed and the test specimen enclosed air space mean temperature is close to that which existed during the test.

**Appendix D: Test Data Sheets (Required Information)**

**Measured Test Data**

Heat Flows

1. Total measured input into metering box ( $Q_{total}$ ) \_\_\_\_\_ W
2. Surround Panel Heat Flow ( $Q_{sp}$ ) \_\_\_\_\_ W
3. Metering Box Wall Heat Flow ( $Q_{mb}$ ) \_\_\_\_\_ W
4. Flanking Loss Heat Flow ( $Q_{fl}$ ) \_\_\_\_\_ W
5. Net Specimen Heat Loss ( $Q_s$ ) \_\_\_\_\_ W

Areas

1. Test Specimen Projected Area ( $A_s$ ) \_\_\_\_\_ m<sup>2</sup>
2. Test Specimen Interior Surface Area ( $A_{int}$ ) \_\_\_\_\_ m<sup>2</sup>
3. Test Specimen Exterior Surface Area ( $A_{ext}$ ) \_\_\_\_\_ m<sup>2</sup>
4. Metering Box Opening Area ( $A_{mb}$ ) \_\_\_\_\_ m<sup>2</sup>
5. Metering Box Interior Baffle Area ( $A_{b1}$ ) \_\_\_\_\_ m<sup>2</sup>
6. Metering Box Exterior Baffle Area ( $A_{b2}$ ) \_\_\_\_\_ m<sup>2</sup>
7. Surround Panel Interior Exposed Area ( $A_{sp}$ ) \_\_\_\_\_ m<sup>2</sup>

Test Conditions

1. Average Metering Room Ambient Temperature \_\_\_\_\_ °C
2. Average Weather Side Ambient Temperature \_\_\_\_\_ °C
3. Average Guard/Environmental Ambient Temperature \_\_\_\_\_ °C
4. Metering Room Average Relative Humidity \_\_\_\_\_ %
5. Measured Exterior Wind Velocity \_\_\_\_\_ m/s
6. Measured Static Pressure Difference Across Test Specimen \_\_\_\_\_ Pa
7. Surround Panel Thickness \_\_\_\_\_ mm

Surface Temperature Data

1. Specimen Area-weighted interior surface temperature ( $t_1$ ) \_\_\_\_\_ °C
2. Specimen Area-weighted exterior surface temperature ( $t_2$ ) \_\_\_\_\_ °C
3. Area-weighted interior frame surface temperature \_\_\_\_\_ °C
4. Area-weighted exterior frame surface temperature \_\_\_\_\_ °C
5. Area-weighted interior edge-of-glazing surface temperature \_\_\_\_\_ °C
6. Area-weighted exterior edge-of-glazing surface temperature \_\_\_\_\_ °C
7. Area-weighted interior center-of-glazing surface temperature \_\_\_\_\_ °C
8. Area-weighted exterior center-of-glazing surface temperature \_\_\_\_\_ °C

**•Results**

1. Thermal Transmittance of test specimen ( $U_s$ ) \_\_\_\_\_ W/m<sup>2</sup>•K
2. Standardized Thermal Trans. of Test Specimen ( $U_{staw}$ ) \_\_\_\_\_ W/m<sup>2</sup>•K
3. Standardized Thermal Trans. of Test Specimen ( $U_{stcts}$ ) \_\_\_\_\_ W/m<sup>2</sup>•K

**Calculated Test Data**

Method A (Modified) Procedure

- |   |       |                     |
|---|-------|---------------------|
| 1. Room Side Surface Conductance ( $h_I$ )                      | _____ | W/m <sup>2</sup> •K |
| 2. Weather Side Surface Conductance ( $h_{II}$ )                | _____ | W/m <sup>2</sup> •K |
| 3. Test Specimen Thermal Conductance ( $C_S$ )                  | _____ | W/m <sup>2</sup> •K |
| 4. Standardized Thermal Transmittance ( $U_{St}$ )              | _____ | W/m <sup>2</sup> •K |
| 5. Standardized Room Side Surface Conductance ( $h_{StI}$ )     | _____ | W/m <sup>2</sup> •K |
| 6. Standardized Weather Side Surface Conductance ( $h_{StII}$ ) | _____ | W/m <sup>2</sup> •K |

Method B (Equivalent "CTS" Method)

- |  |       |                     |
|--|-------|---------------------|
| 1. Room Side Surface Conductance ( $h_I$ )                       | _____ | W/m <sup>2</sup> •K |
| 2. Weather Side Surface Conductance ( $h_{II}$ )                 | _____ | W/m <sup>2</sup> •K |
| 3. Test Specimen Thermal Conductance ( $C_S$ )                   | _____ | W/m <sup>2</sup> •K |
| 4. Standardized Thermal Transmittance ( $U_{St}$ )               | _____ | W/m <sup>2</sup> •K |
| 5. Convection Coefficient (K)                                    | _____ | W/m <sup>2</sup> •K |
| 6. Radiative Test Specimen Heat Flow ( $Q_{r1}$ )                | _____ | W                   |
| 7. Conductive Test Specimen Heat Flow ( $Q_{c1}$ )               | _____ | W                   |
| 8. Equivalent Room Side Surface Temperature                      | _____ | °C                  |
| 9. Equivalent Weather Side Surface Temperature                   | _____ | °C                  |
| 10. Room Side Baffle Surface Temperature ( $T_{b1}$ )            | _____ | °C                  |
| 11. Cold Side Baffle Surface Temperature ( $T_{b2}$ )            | _____ | °C                  |
| 12. Standardized Room Side Surface Conductance ( $h_{StI}$ )     | _____ | W/m <sup>2</sup> •K |
| 13. Standardized Weather Side Surface Conductance ( $h_{StII}$ ) | _____ | W/m <sup>2</sup> •K |
| 14. Emittance of Glazing ( $e_1$ )                               | _____ |                     |
| 15. Warm Side Baffle Emittance ( $eb_1$ )                        | _____ |                     |

**Note: List results for both methods!**

Test Duration (must be completed in full)

- The environmental systems were started at \_\_\_\_\_ hrs. on \_\_\_\_\_ (date).
- The test parameters were considered stable for two consecutive two hour test periods from \_\_\_\_\_ hrs., \_\_\_\_\_ to \_\_\_\_\_ hrs., \_\_\_\_\_ (date).
- The thermal performance test results were derived from \_\_\_\_\_, hrs., \_\_\_\_\_ to \_\_\_\_\_ hrs., \_\_\_\_\_ (date).

Discuss the method used to determine  $U_{St}$  and explain why that method was chosen

---



---



---

**Surface Temperature and Area Information**

Thermocouple #	<b><u>Individual Measurements</u></b>		<b><u>Area-weighted Measurements</u></b>			
	<i>Individual Surface Temperatures</i>		<i>Assigned Areas per TC Location</i>		<i>Area-weighted Temperatures</i>	
	<i>Interior</i>	<i>Exterior</i>	<i>Interior</i>	<i>Exterior</i>	<i>Interior</i>	<i>Exterior</i>
	(°C)	(°C)	(m <sup>2</sup> )	(m <sup>2</sup> )	(°C)	(°C)
1	_____	_____	_____	_____	_____	_____
2	_____	_____	_____	_____	_____	_____
3	_____	_____	_____	_____	_____	_____
4	_____	_____	_____	_____	_____	_____
5	_____	_____	_____	_____	_____	_____
6	_____	_____	_____	_____	_____	_____
7	_____	_____	_____	_____	_____	_____
8	_____	_____	_____	_____	_____	_____
9	_____	_____	_____	_____	_____	_____
10	_____	_____	_____	_____	_____	_____
11	_____	_____	_____	_____	_____	_____
12	_____	_____	_____	_____	_____	_____
13	_____	_____	_____	_____	_____	_____
14	_____	_____	_____	_____	_____	_____
15	_____	_____	_____	_____	_____	_____
16	_____	_____	_____	_____	_____	_____
17	_____	_____	_____	_____	_____	_____
18	_____	_____	_____	_____	_____	_____
19	_____	_____	_____	_____	_____	_____
20	_____	_____	_____	_____	_____	_____
21	_____	_____	_____	_____	_____	_____
22	_____	_____	_____	_____	_____	_____
23	_____	_____	_____	_____	_____	_____
24	_____	_____	_____	_____	_____	_____
25	_____	_____	_____	_____	_____	_____
26	_____	_____	_____	_____	_____	_____
27	_____	_____	_____	_____	_____	_____
28	_____	_____	_____	_____	_____	_____
29	_____	_____	_____	_____	_____	_____
30	_____	_____	_____	_____	_____	_____

Average interior area-weighted surface temperature \_\_\_\_\_ °C

Average exterior area-weighted surface temperature \_\_\_\_\_ °C

Measured interior surface area \_\_\_\_\_ m<sup>2</sup>

Measured exterior surface area \_\_\_\_\_ m<sup>2</sup>

## **Appendix E: Tubular Daylighting Devices**

**E.0 Tubular Daylighting Devices.** This section presents and references methods for determining specific tubular daylighting device system heat transfer properties or quantities used in the determination of these properties.

Use the simulation procedure below to determine U-factor. There currently are no simulation procedures for SHGC, visible transmittance, or condensation.

There currently are no simulation procedures for U-factor, SHGC, visible transmittance, or condensation.

**E.1 Orientation.** U-Factors for tubular daylighting devices shall be rated on a horizontal orientation. The diffuser is simulated attached to the ceiling, the tubular section located in the attic space connecting the interior diffuser to the exterior dome, and the exterior dome mounted to the roof deck, therefore the heat flow shall be in the vertical direction. Standardized rating conditions are defined in Section E.5.

**E.2 Rating Sizes.** The tubular daylighting device size listed in Table 1 is based on a standardized 350 mm diameter tube opening.

**E.3 Tubular Daylighting Device Area.** The U-factor for all tubular daylighting devices is based on the tube diameter and the corresponding area associated with that diameter, which is  $0.096 \text{ m}^2$  ( $1.04 \text{ ft}^2$ ). This area shall be used when calculating the total product U-factor.

**E.4 Product Line.** A tubular daylighting device product line shall only consist of individual products of the same tube material, exterior dome material and interior diffuser material.

### **E.5 Standard Modeling Conditions.**

1. 750 mm shaft length (interior ceiling line to exterior roof line).
2. 350 mm diameter shaft opening.
3. Convective correlation in the shaft air cavity.
4. Ceiling insulation to be simulated as R-5.3 fiberglass batt insulation, 250 mm total depth.
5. An exterior 13 mm thick plywood roof deck.
6. ASHRAE attic space boundary conditions on the exterior (outside) surface of the vertical shaft material, from the top of the insulation material to the underside of the 13 mm plywood roof deck.

**E.6 Approved Total Fenestration Product U-factor Calculation Procedure.** The total tubular daylighting system U-factor shall be calculated as outlined below:

- (a) Use the tubular shaft area in square meters, to the nearest  $0.001 \text{ m}^2$  (which is  $0.096 \text{ m}^2$  for a 350 mm diameter product).

- (b) Perform the following calculations as shown in Equation C2:
- (1) Multiply the tubular shaft area U-factor by its corresponding area;
  - (2) Divide this total by the projected total tubular daylighting device interior opening area to produce computed total product U-factor.

$$U_t = (U_{td} * A_{td}) / A_{ds}$$

[Equation C2]

Where:

$U_t$  = Total Tubular Daylighting System U-factor

$U_{td}$  = Tubular Daylighting System U-factor

$A_{td}$  = Tubular Daylighting System Area

$A_{ds}$  = Projected Total Tubular Daylighting Device Shaft Interior Opening Area