



**UNIVERSITY OF MASSACHUSETTS AMHERST**

*Center for Energy Efficiency and Renewable Energy*

Engineering Laboratory Building, Box 32210

Amherst, MA 01003-2210

---

**Technical Report:**

---

**Computer Modeling Results for NFRC Simulation  
Round Robin 1999 (SRR99) Window Using THERM  
and WINDOW Software**

---

*Submitted by:* **Dr. Dragan Curcija**  
**Alan Leung, Research Assistant**

**January, 2001**

## NFRC Simulation Round Robin

The NFRC Simulation Round Robin 1999 was a thermally unbroken Aluminum horizontal sliding window, with low-E double-glazing. The residential NFRC AA size was used. Therm 2.1 and Window 4.1 software programs were used to model thermal performance of this window. In addition to standard NFRC simulation, an additional modeling was performed by applying detailed radiation model on indoor boundary.

Both cases consisted of modeling the window at a 90° tilt with the material thermal-physical properties given in Table 1. Figure 1 shows materials used in window construction

**Table 1: Material thermal-physical properties of aluminum horizontal slider**

Material	$k$ (Btu/h-ft-F)	$e$
Aluminum exposed	92.45	0.9
Aluminum enclosed	92.45	0.2
Vinyl (flexible)	0.069	0.9
Polysulphide	0.11	0.9
Mohair sweep	0.081	0.9
Glass - clear	0.52	0.84
Glass - low-E	0.52	0.096
Silica Gel	0.017	0.9
Butyl Rubber	0.139	0.9

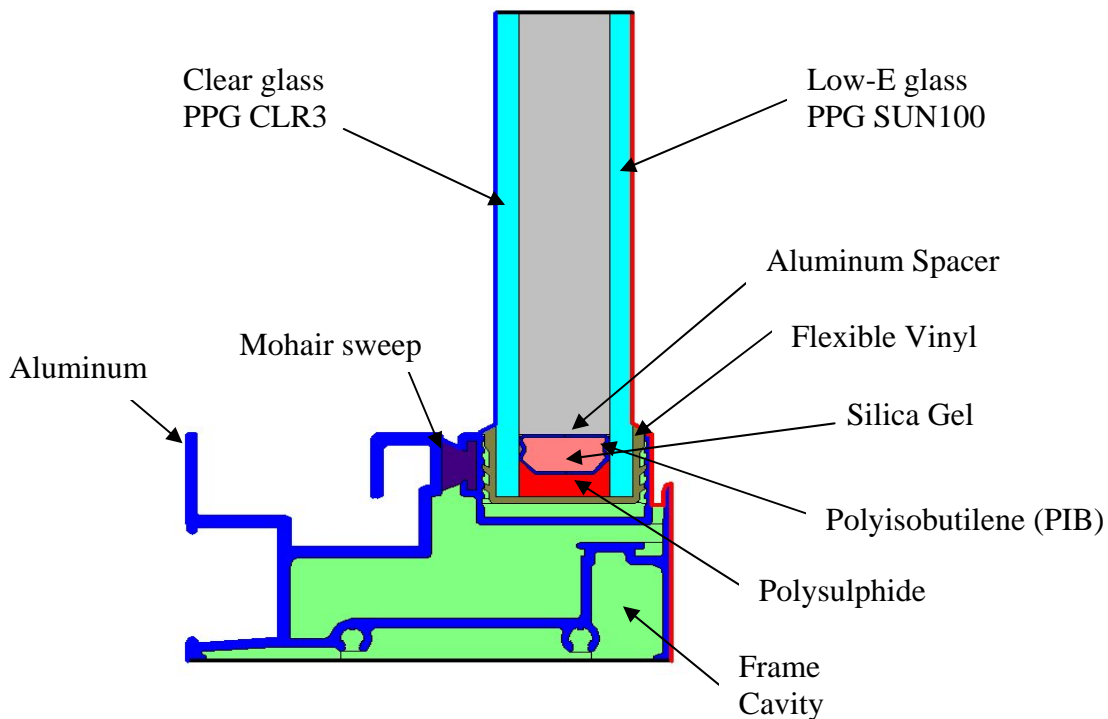

**Figure 1: Materials Used in Window Construction**

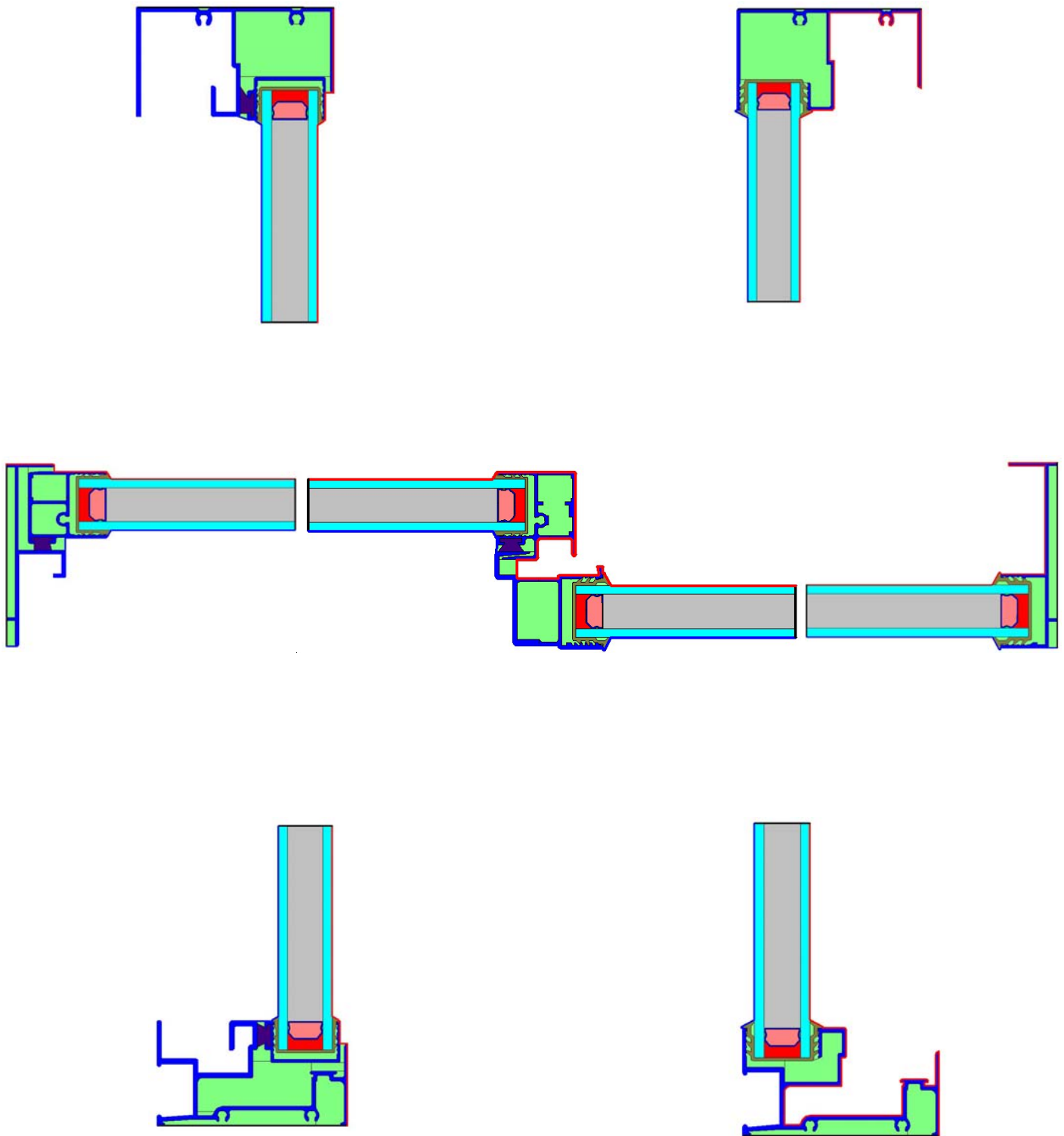

**Figure 2.** Layout of the Cross-Sections for Horizontal Slider

Figure 2 shows the layout of individual cross-sections and location of indoor and outdoor environment. The horizontal slider has 7 typical cross-sections, which were each modeled separately in THERM 2.1 computer program. In addition, divider cross-section was modeled in order to calculate heat transfer results for window with dividers.

Window 4.1 computer program was used to calculate thermal indices (i.e., U-Factor, SHGC, and VT) of the insulated glazing unit (IGU). IGU was made of double glazing, made of PPG’s low-e glass S100CL 3.PPG (nominal thickness - 0.129 inches) and PPG’s clear glass Clear 3.PPG (nominal thickness - 0.129 inches) and a gas mixture composed of 10% Air and 90% Argon. The overall thickness of this IGU was 0.75 inches. Results of thermal analysis for this IGU is given in Appendix 1.

The frame is made of thermally unbroken Aluminum. Frame and edge of glass cross-sections were modeled according to the THERM NFRC Simulation Training Manual for the case using standard NFRC conditions. In addition, this window was modeled with radiation enclosure to better account for the radiative heat transfer effects.

Table 2 lists boundary conditions used in modeling the SRR99 horizontal slider. For IGU, convective and radiative parts of surface heat transfer coefficient were calculated in WINDOW 4.1 and transferred to THERM as overall surface heat transfer coefficient. Overall frame surface heat transfer coefficient is prescribed by THERM NFRC Simulation manual (NFRC 1999).

**Table 2: Boundary conditions with standard NFRC conditions**

<i>Boundary Conditions</i>		<i>Environmental Temperature (°F)</i>	<i>h<sub>c</sub></i>	<i>h<sub>r</sub></i>	<i>Overall h</i>	<i>ε</i>
			<i>(Btu/h-ft<sup>2</sup>-F)</i>			
Outdoor Side	Glazing	0	N/A	N/A	5.112	0.84
	Frame		N/A	N/A	5.112	0.90
Indoor Side	Glazing	70	0.730	0.611	1.341	0.84
	Frame		0.610	0.851	1.461	0.90

In the case of radiation enclosure, radiative components on the frame and edge of glass indoor sections were calculated by the program. They are not listed in Table 2, because they vary by each segment of the finite element mesh and would be too numerous to list them.

## Results

Eight laboratories participated in the Round Robin test and the total U-factor values ranged between 0.56 Btu/hr-ft<sup>2</sup>-°F to 0.58 Btu/hr-ft<sup>2</sup>-°F, with an average U-factor value of 0.57 Btu/hr-ft<sup>2</sup>-°F. This was comparable to the U-factor value of 0.58 Btu/hr-ft<sup>2</sup>-°F (without dividers) obtained computationally by Therm 2.1 and Window 4.1. With two horizontal and two vertical dividers on each glazing system, the U-factor increased to 0.66 Btu/hr-ft<sup>2</sup>-°F.

The individual U-factors and total U-factors (with and without dividers) for the two cases are shown in Table 3. Figures 3 to 10 show temperature distributions and U-factors for each cross section, using both “Standard NFRC” and “Detailed Radiation” boundary conditions. Appendix contains printout from WINDOW 4.1 program results, given in two characteristic outputs (WINDOW 4.1 and NFRC). Outputs from WINDOW 4.1 include results of calculations for glazing systems, details about

glazing layers, and overall window results, including listing of frame and edge of glass, as well as divider and divider edge U-factors. The results in appendix are listed for both “Standard NFRC” and “Detailed Radiation” models.

**Table 3: Frame, Edge and Total U-factors for NFRC and detailed radiation model cases**

<b>Cross Section</b>	<b>NFRC U-factors (Btu/hr-ft<sup>2</sup> - °F)</b>		<b>Detailed Radiation Model U-factors (Btu/hr-ft<sup>2</sup> - °F)</b>	
	<i>Frame</i>	<i>Edge</i>	<i>Frame</i>	<i>Edge</i>
Fixed Head (hf)	2.454	0.363	2.018	0.349
Vented Head (hv)	1.383	0.446	1.274	0.440
Vented Jamb (jv)	1.347	0.446	1.240	0.439
Vented Sill (sv)	1.376	0.449	1.268	0.441
Fixed Sill (sf)	3.632	0.384	2.730	0.367
Fixed Jamb (jf)	2.727	0.362	2.324	0.340
Meeting Rail (mr)	2.821	0.390	2.155	0.387
Divider (dv)	0.649	0.353	0.649	0.353
<i>Total U-factor with dividers</i>	<i>0.66</i>		<i>0.60</i>	
<i>Total U-factor without dividers</i>	<i>0.58</i>		<i>0.53</i>	

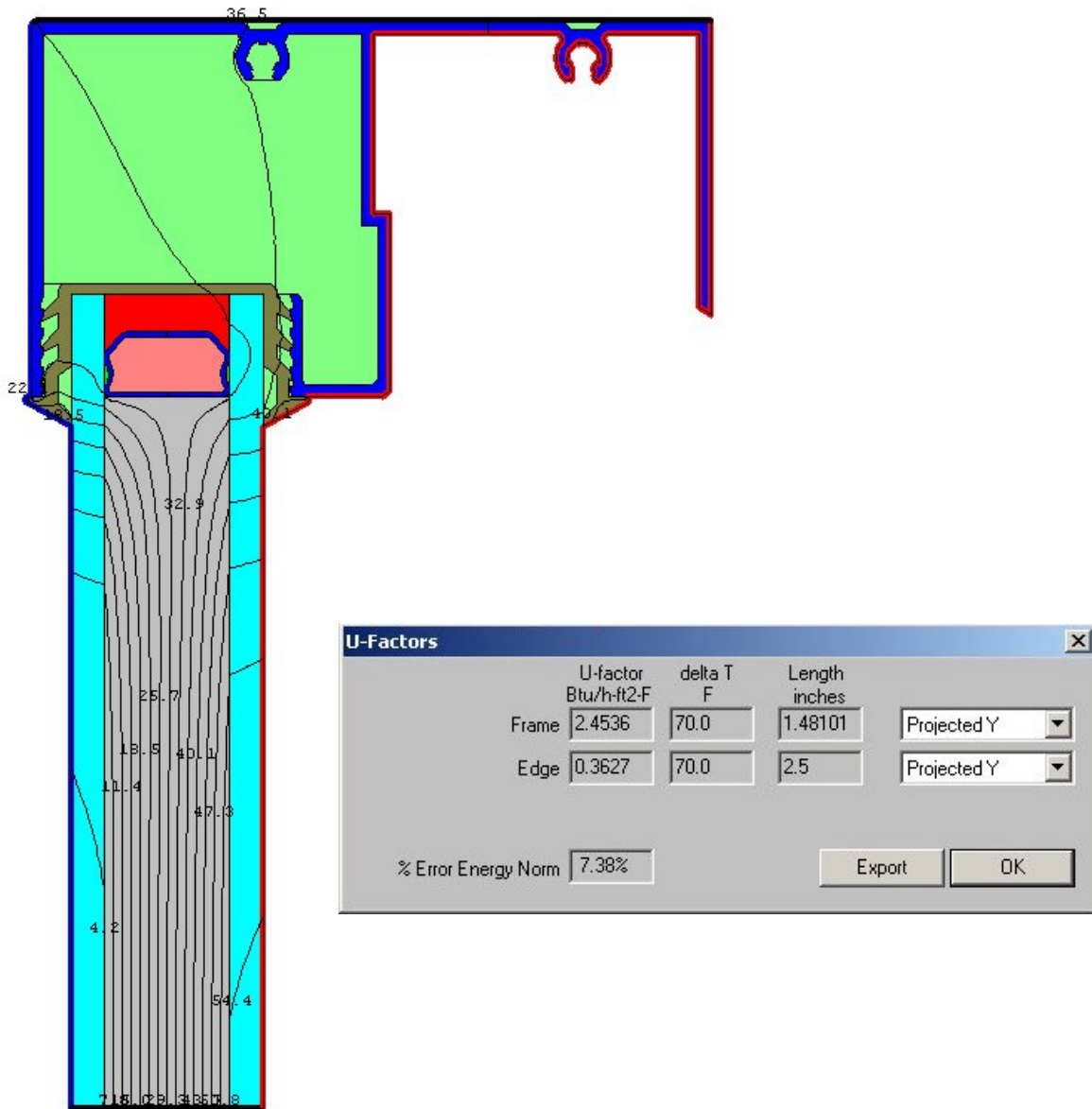

Figure 3a. Aluminum Horizontal Slider – Fixed Head Cross Section (Standard NFRC BCs)

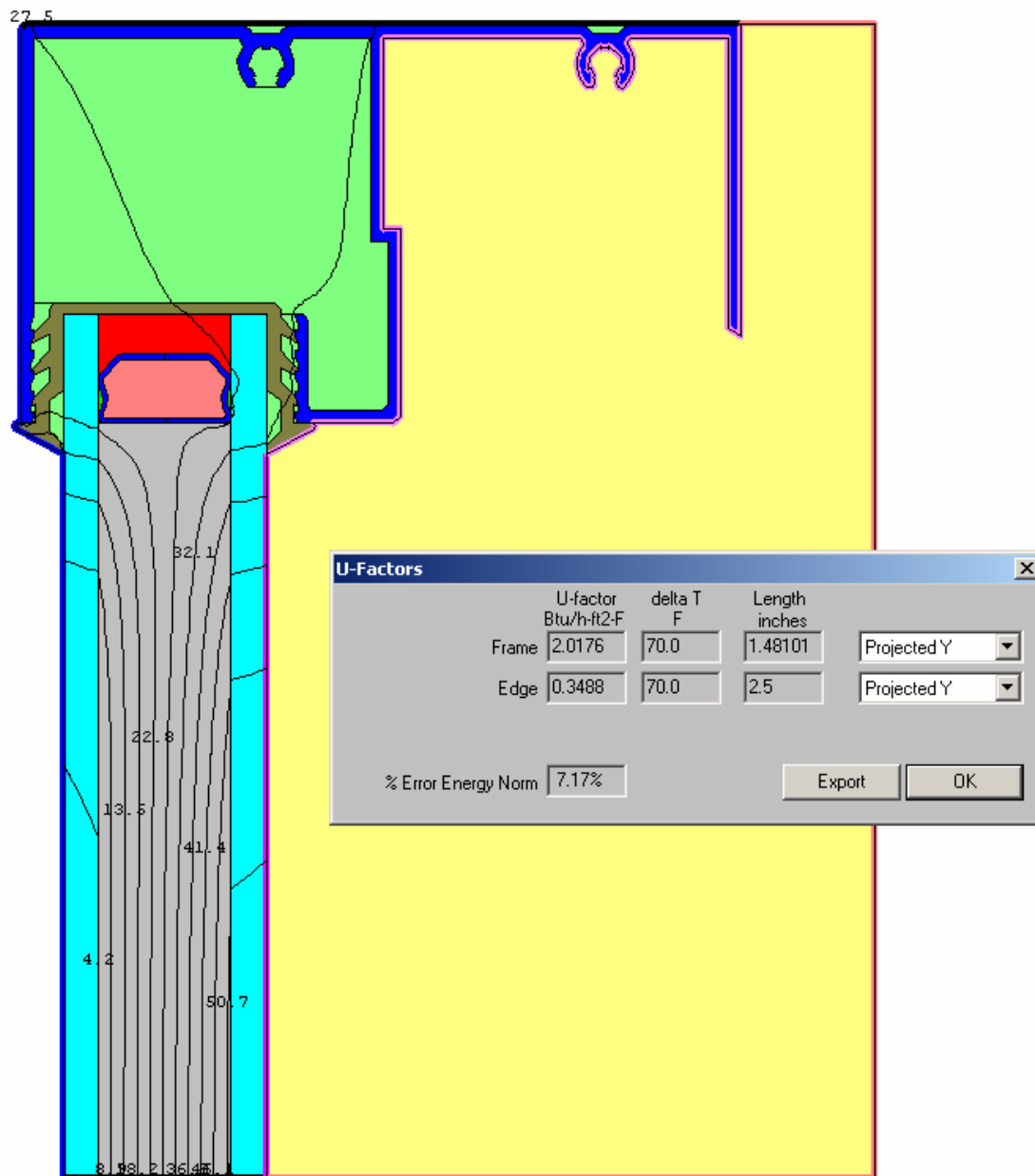

Figure 3b. Aluminum Horizontal Slider – Fixed Head Cross Section (Detailed Radiation BCs)

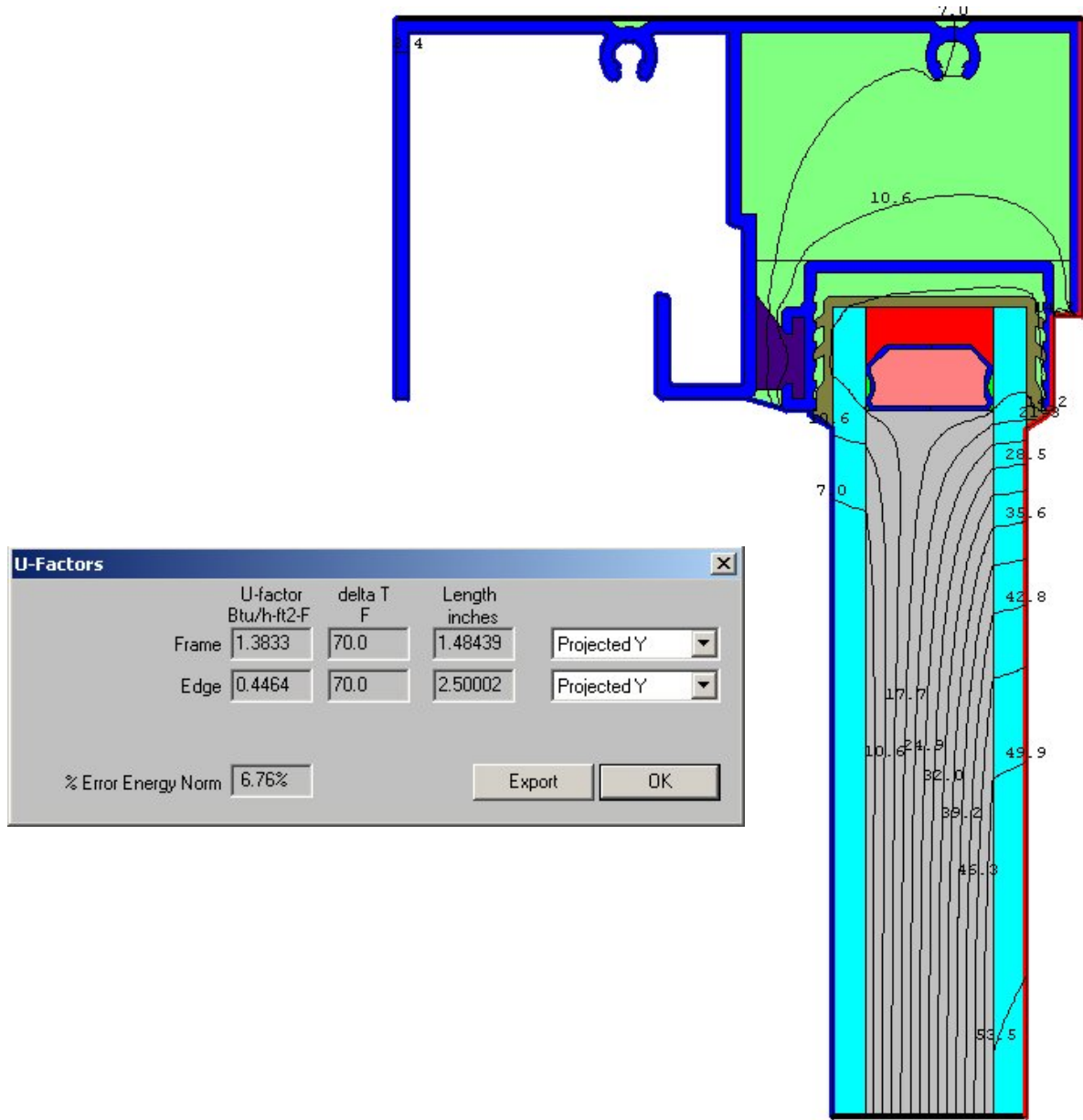

Figure 4a. Aluminum Horizontal Slider – Vented Head Cross Section (Standard NFRC BCs)

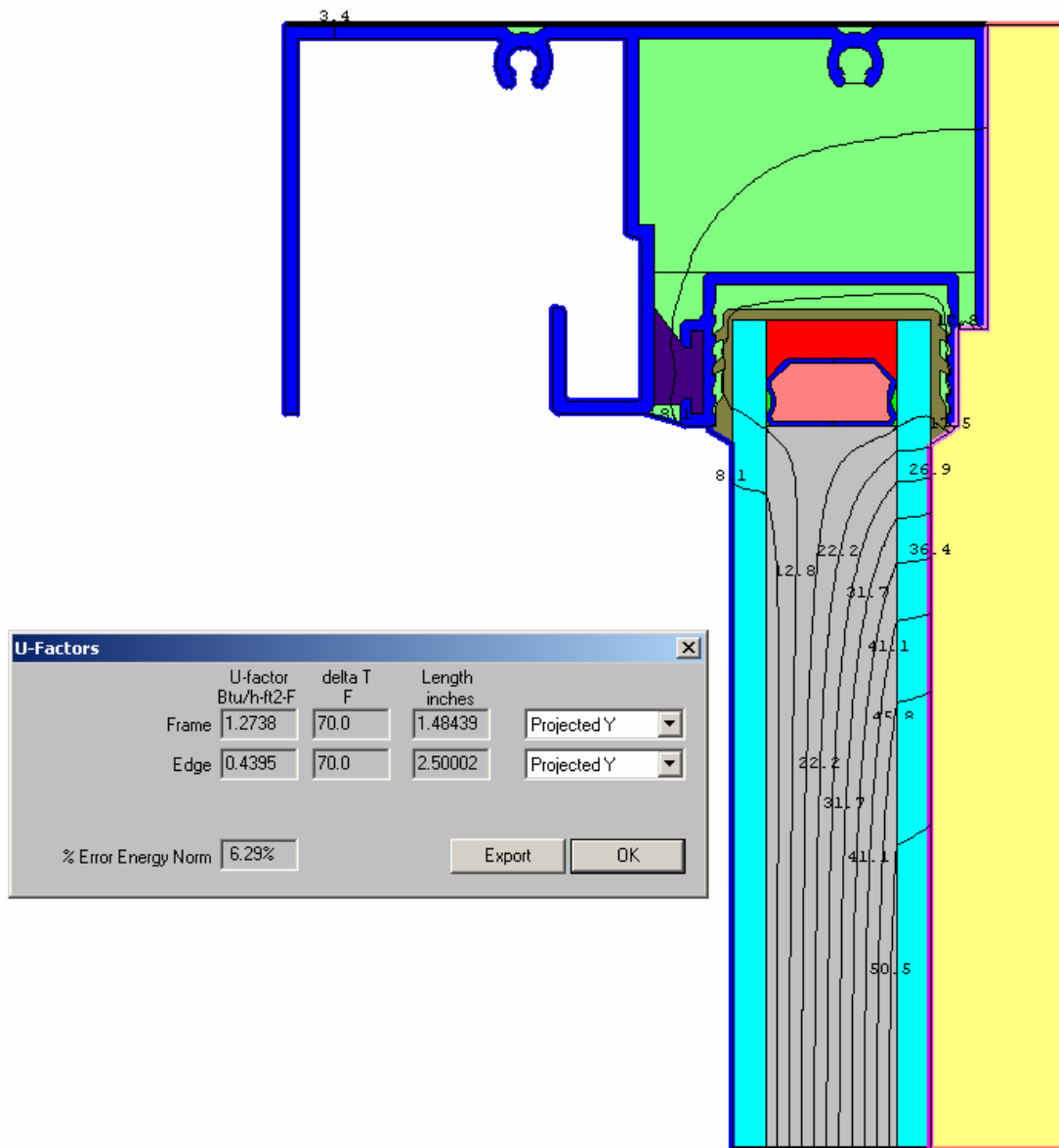

Figure 4b. Aluminum Horizontal Slider – Vented Head Cross Section (Detailed Radiation BCs)

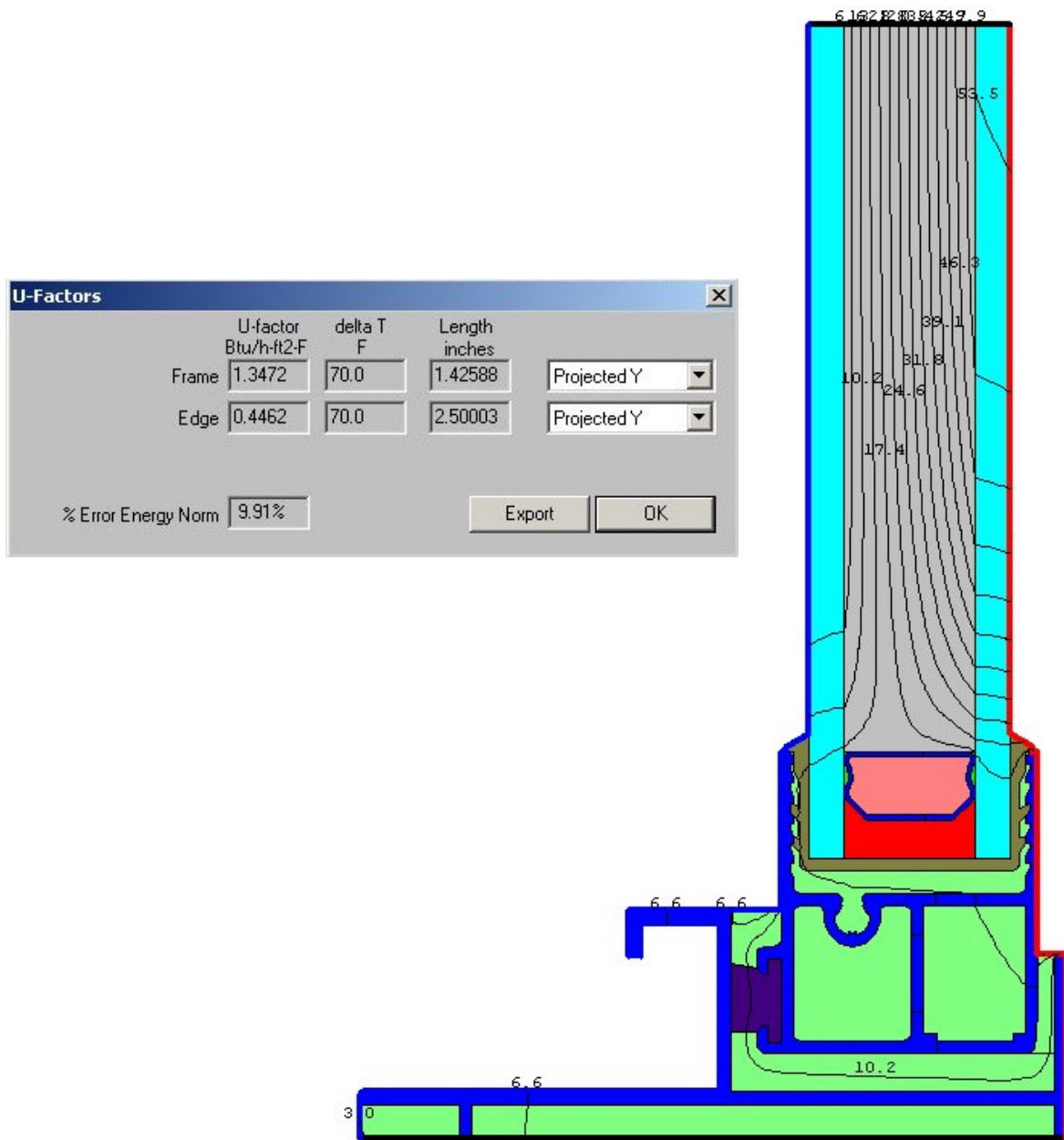

Figure 5a. Aluminum Horizontal Slider – Vented Jamb Cross Section (Standard NFRC BCs)

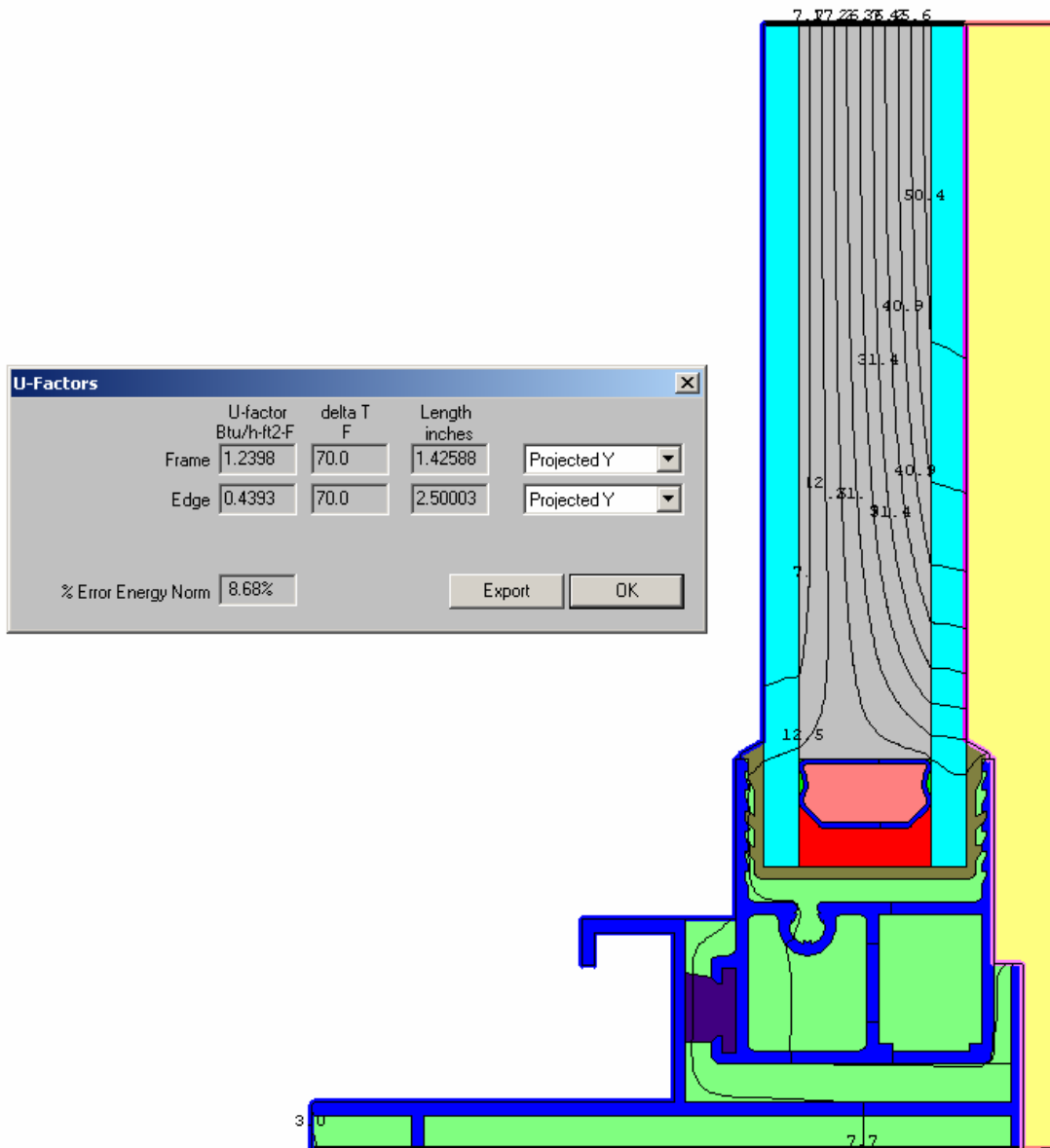

Figure 5b. Aluminum Horizontal Slider – Vented Jamb Cross Section (Detailed Radiation BCs)

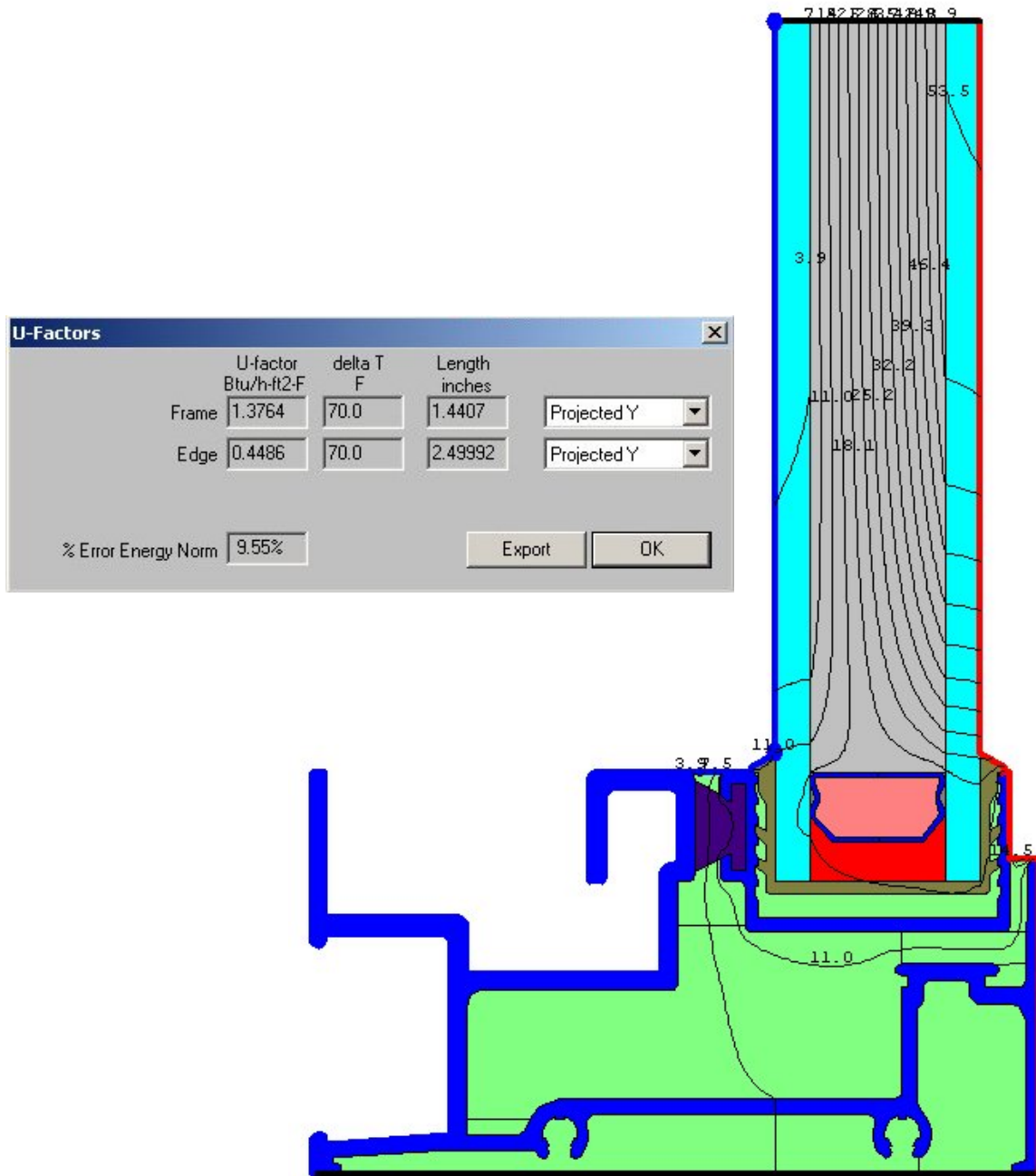

Figure 6a. Aluminum Horizontal Slider – Vented Sill Cross Section (Standard NFRC BCs)

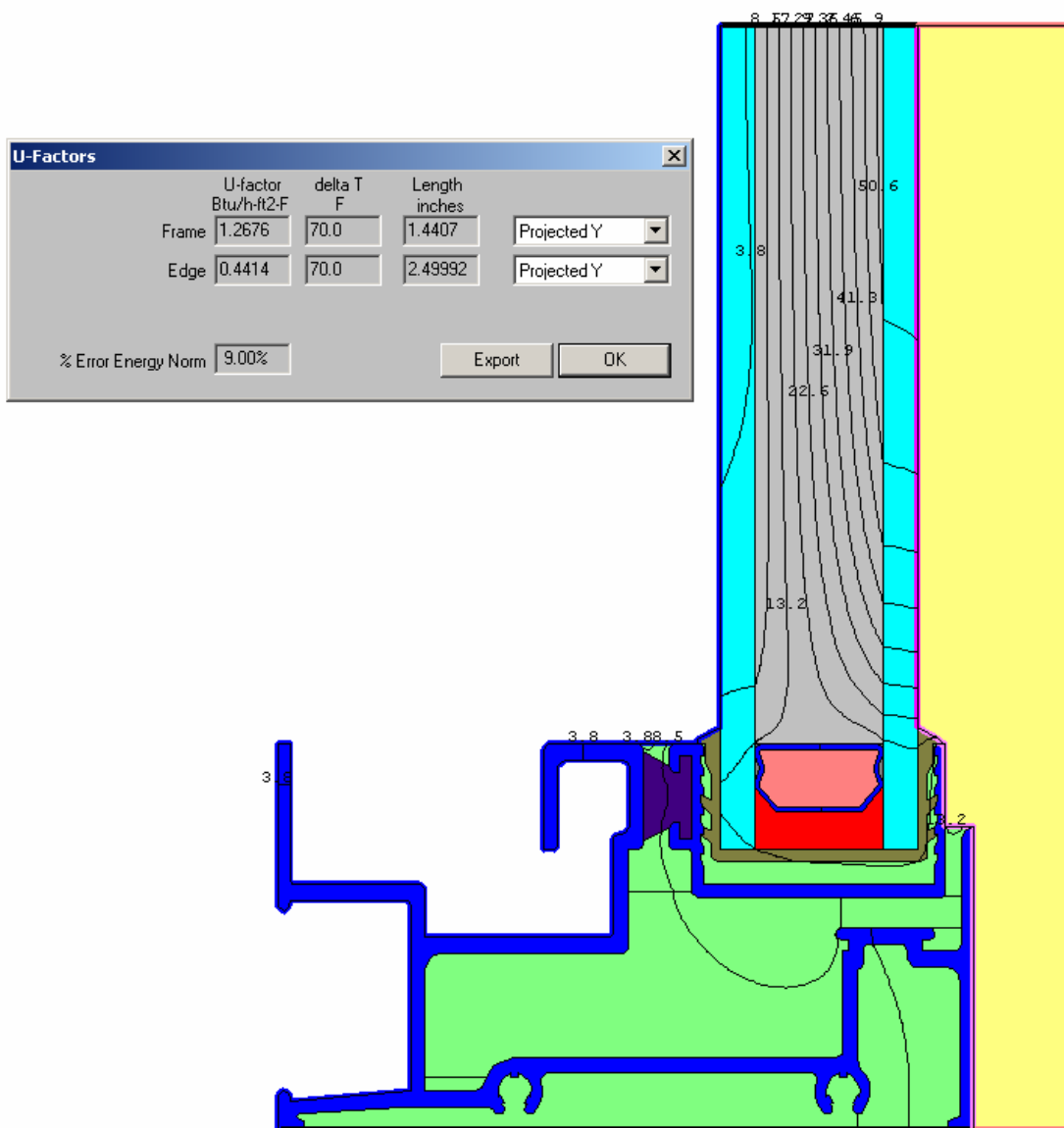

Figure 6b. Aluminum Horizontal Slider – Vented Sill Cross Section (Detailed Radiation BCs)

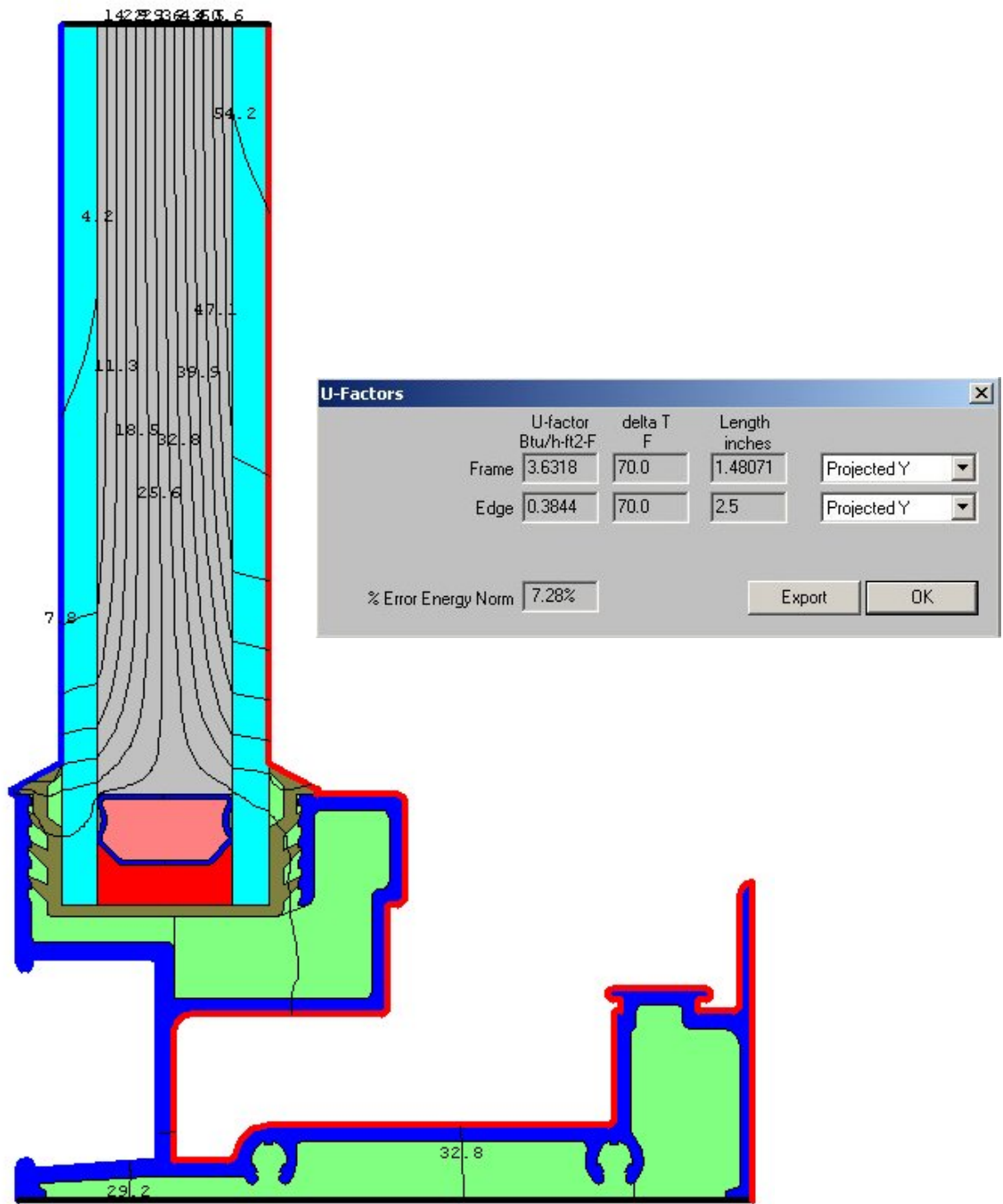

Figure 7a. Aluminum Horizontal Slider – Fixed Sill Cross Section (Standard NFRC BCs)

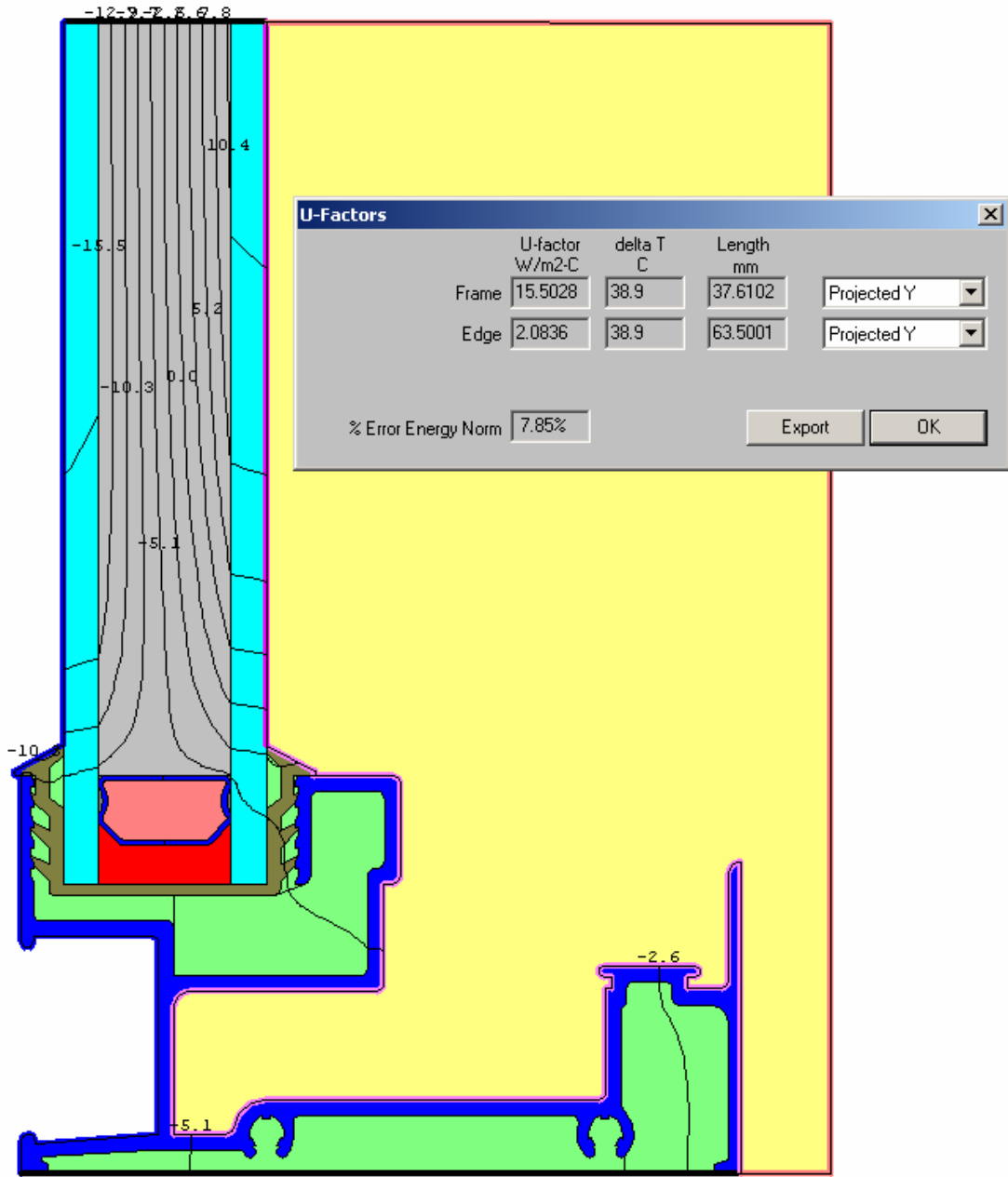

Figure 7b. Aluminum Horizontal Slider – Fixed Sill Cross Section (Detailed Radiation BCs)

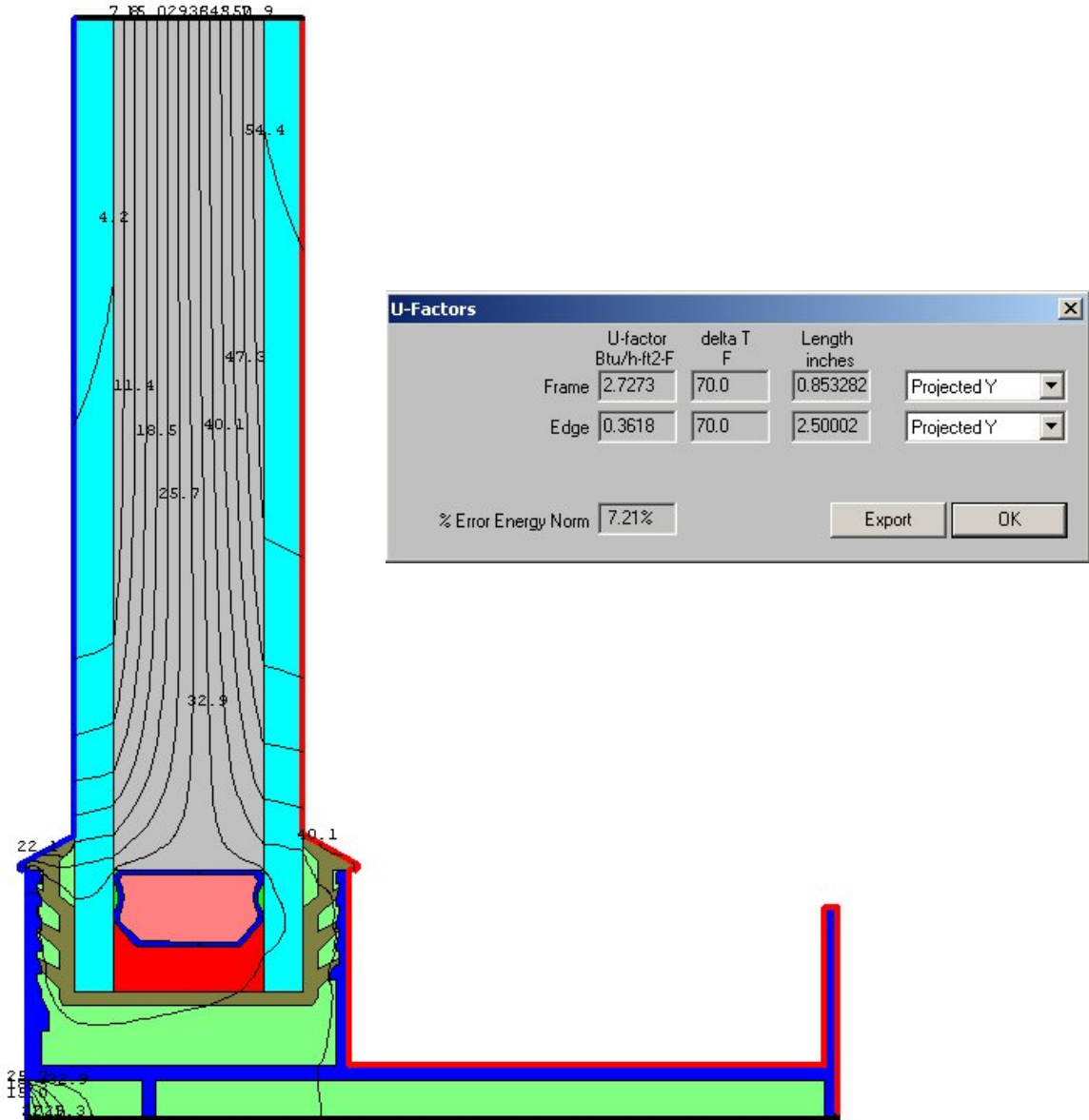

Figure 8a. Aluminum Horizontal Slider – Fixed Jamb Cross Section (Standard NFRC BCs)

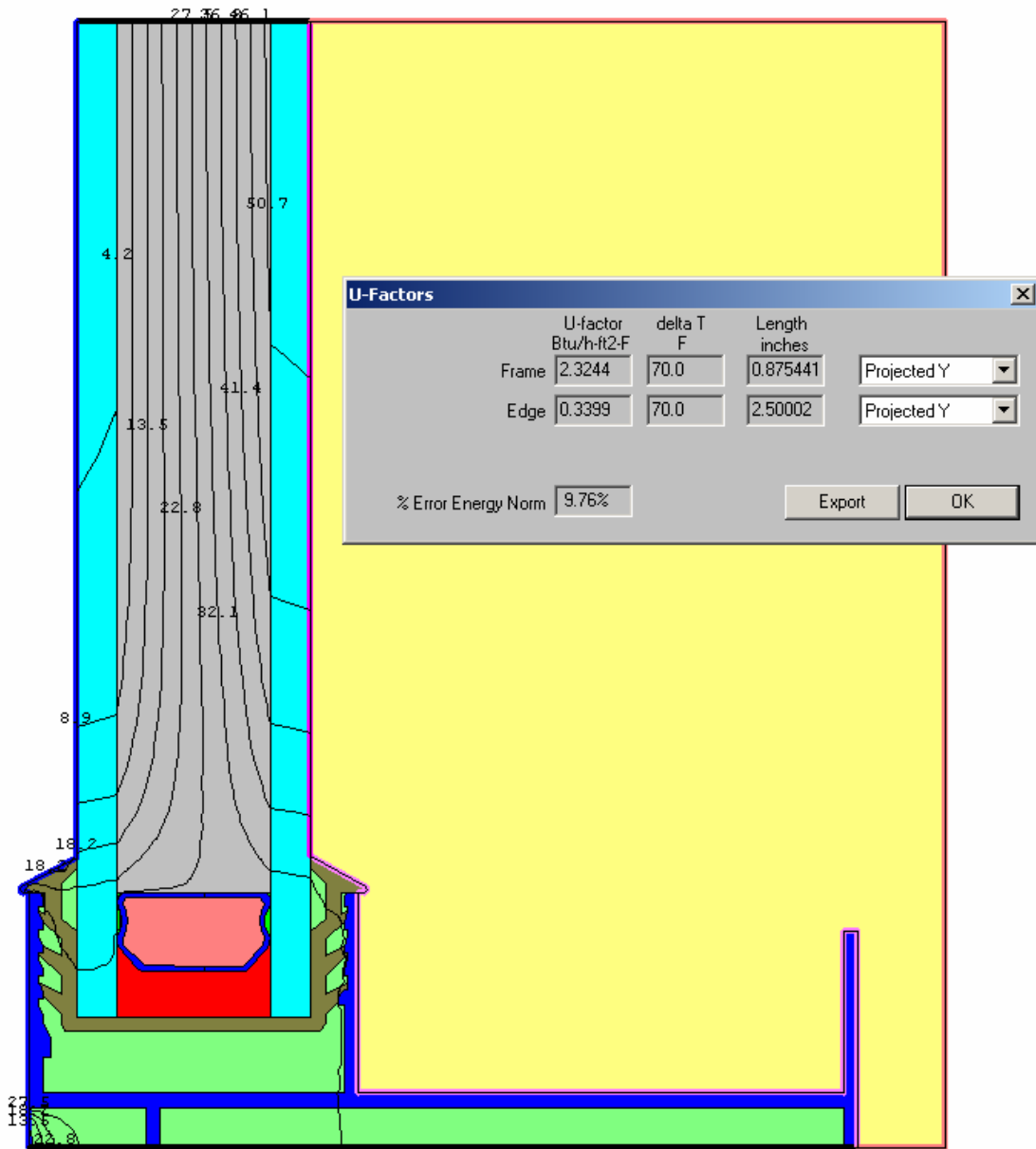

Figure 8b. Aluminum Horizontal Slider – Fixed Jamb Cross Section (Detailed Radiation BCs)

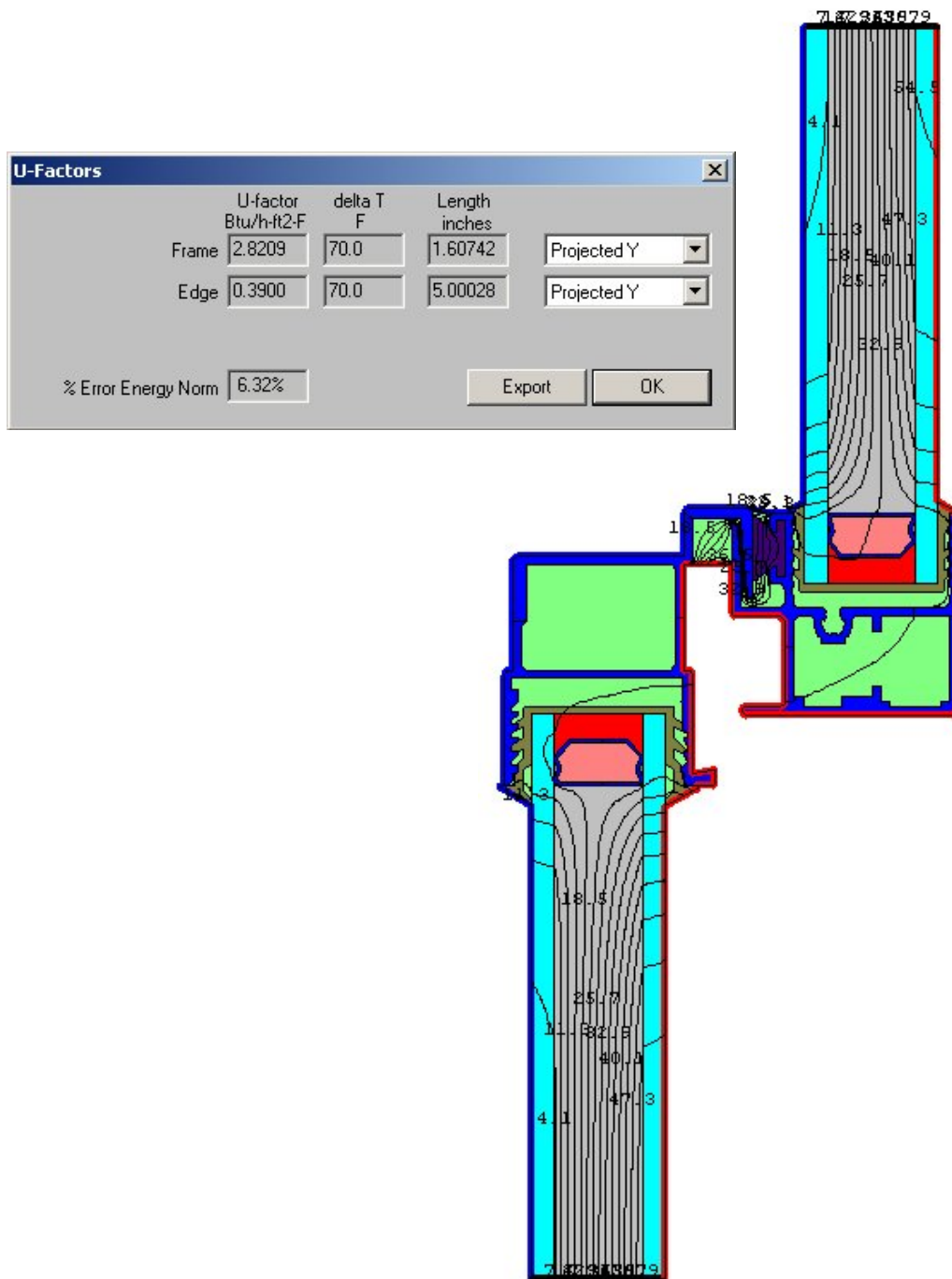

Figure 9a. Aluminum Horizontal Slider – Meeting Rail Cross Section (Standard NFRC BCs)

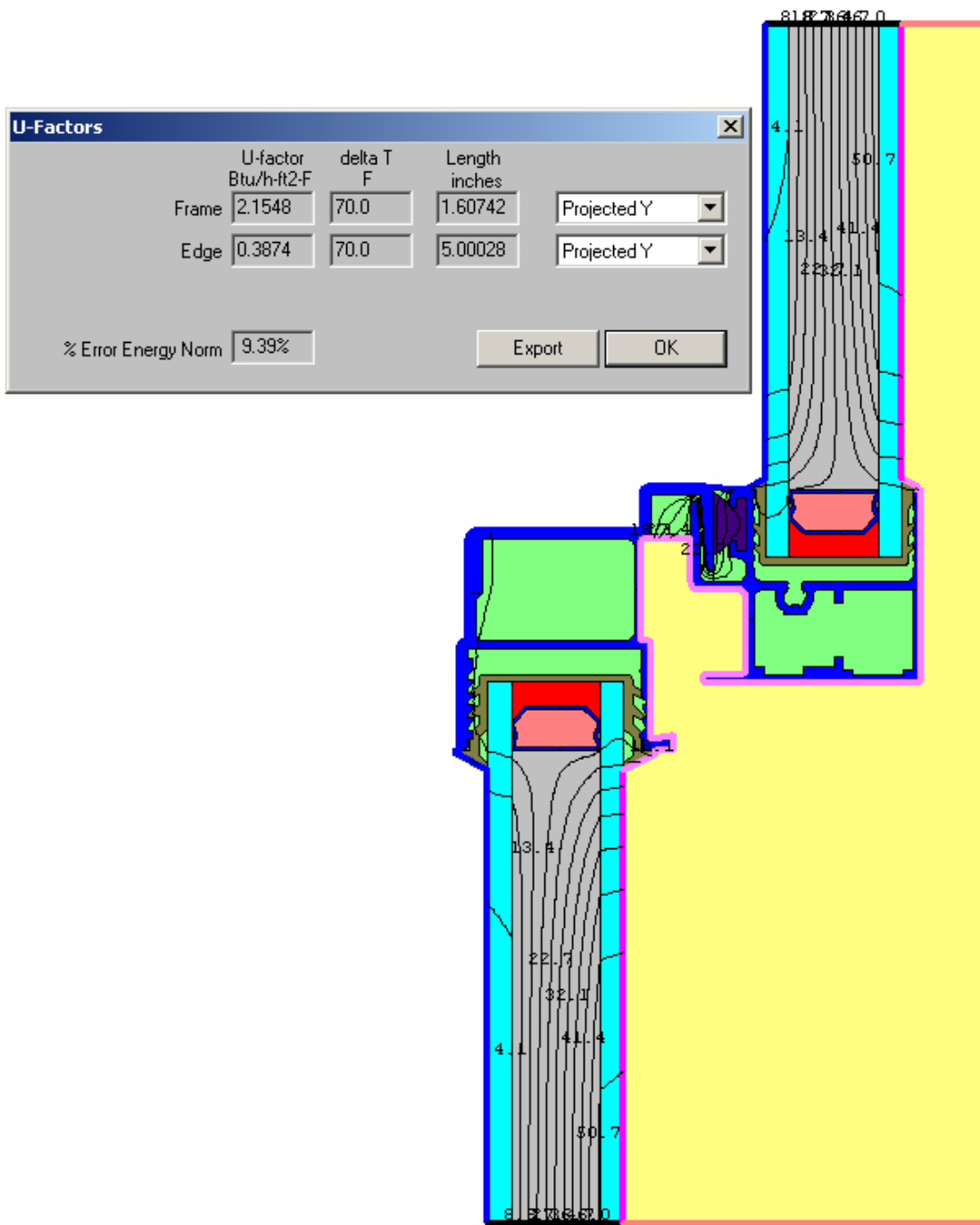

Figure 9b. Aluminum Horizontal Slider – Meeting Rail Cross Section (Detailed Radiation BCs)

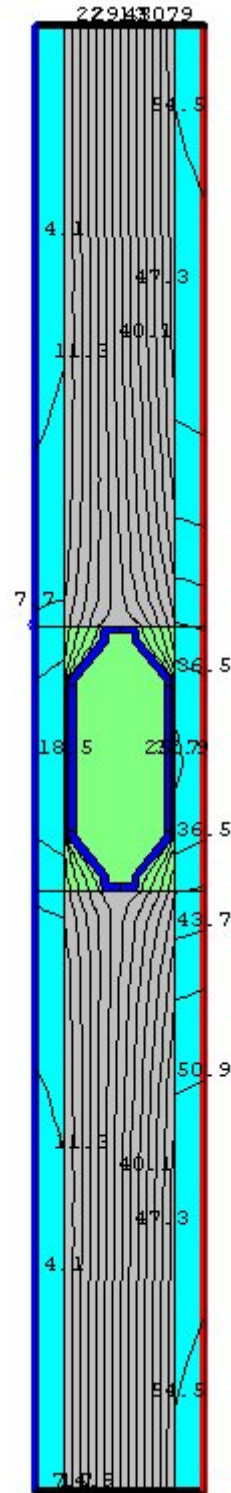
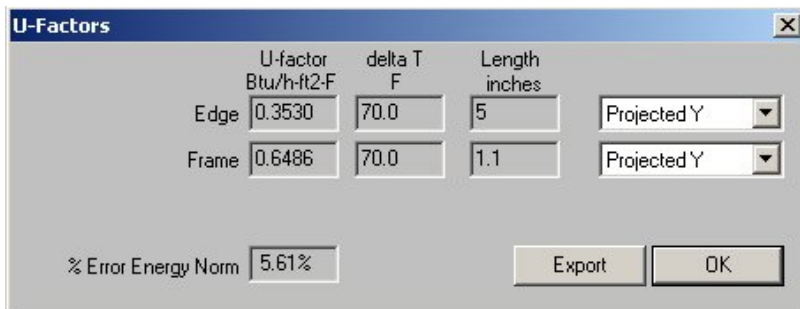

Figure 10. Aluminum Horizontal Slider – Divider

# APPENDIX 1: Window 4.1 Output Files

## 1-A. Aluminum Horizontal Slider With Dividers (Standard NFRC Model)

### 1-A-1. WINDOW 4.1 Report

WINDOW 4.1 Report Page 1 01/05/01 08:43:54  
 ID:1 FrID: 7 FrID: 8  
 Name:srr99d-hsld  
 Mode:Design  
 EnvCond:1  
 Type:Horz Slider FrID: 9  
 Tilt: 90  
 Size:Horz Slid AA  
 Width: 60.00"  
 Height: 36.00"  
 Area: 15.00 ft2  
 U-value: 0.655 Btu/h-ft2-F  
 SC: 0.537  
 SHGC: 0.462  
 Vt: 0.551

GlzSysID: 11	GlzSysID: 11
Wid:29.48"	Wid:26.63"
Div ID: 7	Div ID: 7
#H: 2 #V: 2	#H: 2 #V: 2
FrID: 11	

FrID: 12 FrID: 13

#### Data for Glazing Systems

ID	Name	COG Area ft2	#Lay	Tilt	Uc Btu/h-ft2	SCc	SHGCc	Vtc	RHG
11	dhs-gl	1.351	2	90	0.272	0.62	0.53	0.75	128
11	dhs-gl	1.040	2	90	0.272	0.62	0.53	0.75	128

#### Glass and Gas Data for Glazing System '11 dhs-gl'

ID	Name	D(in)	Tsol	1 Rsol	2 Tvis	1 Rvis	2 Tir	1 Emis	2 Keff			
Outside												
5142FS100CL_3.PPG	#	0.129	.566	.210	.270	.827	.061	.046	.000	.843	.096	.520
8	Air/Argon/Kryp	0.492	Air:	10%	Ar:	90%	Kr:	0%				.015
5009	CLEAR_3.PPG	0.129	.827	.076	.076	.898	.086	.086	.000	.840	.840	.520
Inside												

#### Frame Data

Location	ID	Name	Source	Frame Area ft2	Edge Area ft2	Uframe Btu/h-ft2-F	Uedge
Left Jamb	9	SRR99_JF.T2W	FRAME Jamb	0.205	0.492	2.7273	0.3618
Left Header	7	SRR99_HF.T2W	FRAME Head	0.316	0.430	2.4536	0.3627
Mullion	11	SRR99_MR.T2W	FRAME Rail	0.369	0.985	2.8209	0.3900
Left Sill	12	SRR99_SF.T2W	FRAME Sill	0.316	0.430	3.6318	0.3844
Right Header	8	SRR99_HV.T2W	FRAME Head	0.290	0.381	1.3833	0.4464
Right Jamb	10	SRR99_JV.T2W	FRAME Jamb	0.342	0.493	1.3472	0.4462
Right Sill	13	SRR99_SV.T2W	FRAME Sill	0.282	0.381	1.3764	0.4486

ID	Name	Source	Divider Area ft2	Edge Area ft2	Udiv Btu/h-ft2-F	Udivedge Btu/h-ft2-F
7	SRR99_DV.T2W	FRAME Divide	0.922	2.647	0.6486	0.3530
7	SRR99_DV.T2W	FRAME Divide	0.879	2.452	0.6486	0.3530

Gas Data

ID	Name	Cond Btu/h-ft-F	dCond Btu/h-ft-F2	Visc lb-s/ft2	dVisc lb-s/ft2-F	Dens lb/ft3	dDens lb/ft3-F	Pran	dPran
			x e-5	x e-5	x e-8				
8	Air/Argon/Kryp	Air: .0101	10% 1.7324	Argon: 0.0442	90% 0.0756	Kryp: 0.1081	0% -0.0002	.6840	.00043

No gas data for Single Glazing

Environmental Conditions: 1 NFRC/ASHRAE

	Tout (F)	Tin (F)	WndSpd (mph)	Wnd Dir	Solar (Btu/h-ft2)	Tsky (F)	Esky (F)
Uvalue	0.0	70.0	15.00	Windward	0.0	0.0	1.00
Solar	89.0	75.0	7.50	Windward	248.2	89.0	1.00

Frame Library Data

ID	Name	Source	U-value Frame Btu/h-ft2-F	U-value Edge Btu/h-ft2-F	Edge Corr	GlzSys Width in	GlzSys Uc Btu/h-ft2-F	Width (PFD) in	Abs
9	SRR99_JF.T2W	FRAME Jamb	2.73	0.36	N/A	0.7500	0.272	0.853	0.50
7	SRR99_HF.T2W	FRAME Head	2.45	0.36	N/A	0.7500	0.272	1.481	0.50
11	SRR99_MR.T2W	FRAME Rail	2.82	0.39	N/A	0.7500	0.272	1.607	0.50
12	SRR99_SF.T2W	FRAME Sill	3.63	0.38	N/A	0.7500	0.272	1.481	0.50
8	SRR99_HV.T2W	FRAME Head	1.38	0.45	N/A	0.7500	0.272	1.484	0.50
10	SRR99_JV.T2W	FRAME Jamb	1.35	0.45	N/A	0.7500	0.272	1.426	0.50
13	SRR99_SV.T2W	FRAME Sill	1.38	0.45	N/A	0.7500	0.272	1.441	0.50

ID	Name	Source	U-value		Edge Corr	GlzSys Width in	GlzSys Uc Btu/h- ft2-F	Width (PFD) in	Abs
			Div Btu/h- ft2-F	Edge Btu/h- ft2-F					
7	SRR99_DV.T2W	FRAME Divide	0.65	0.35	N/A	0.7500	0.272	1.100	0.50

Optical Properties for Glazing System '11 dhs-gl'

Angle    0    10    20    30    40    50    60    70    80    90    Hemis

Vtc : 0.746  
 Rf : 0.120  
 Rb : 0.124

Tsol : 0.474  
 Rf : 0.239  
 Rb : 0.269

Abs 1: 0.231  
 Abs 2: 0.056  
 Abs 3:  
 Abs 4:  
 Abs 5:  
 Abs 6:  
 SHGCc: 0.534

SCc: 0.62 Color Properties    DomWL    Purity    L\*    a\*    b\*  
 Tdw: N/A Transmittance    um    %  
 Tuv: N/A Reflectance    um    %

Temperature Distribution (degrees F) for '11 dhs-gl'

Env. Conditions:	1 NFRC/ASHRAE	U-value	Condensation		Solar
			RH		
	Outside Air	0.0			89.0
	Outer Surface	3.8	N/A		102.2
Layer 1	Center	4.0			102.7
	Inner Surface	4.2			102.7
	Outer Surface	55.7			88.7
Layer 2	Center	55.9			88.6
	Inner Surface	56.1	61.3%		88.4
	Inside Air	70.0			75.0

# 1-A-2. NFRC Report

WINDOW 4.1 NFRC Report Page 1/1 01/05/01 08:49:27  
 \*\* Design Mode \*\* Library Path: \NFRC\ROUNDNR~1\SRR99&~1\HORSLID\W4LIB\

=====

ID: 1 W: 60.00" H: 36.00" Proj Area: 15.00 ft2  
 Name: srr99d-hsld Type: Horz Slider Vis Trans: 0.55  
 U-value: 0.66 Btu/h-ft2-F SHGC: 0.46

=====

Glazing System Summary

ID Name	Area(ft2)	Width(in)	Uc (Btu/h-ft2-F)	SHGCc
11 dhs-gl	1.351	0.7500	0.2717	0.53
11 dhs-gl	1.040	0.7500	0.2717	0.53
Total COG Area		2.391		

=====

## Frame Summary

Part ID Name	Frame Area (ft2)	Edge Area (ft2)	Uframe (Btu/h-ft2-F)	Uedge (Btu/h-ft2-F)	Abs Spacer	Info
LJ 9 SRR99_JF.T2W	0.205	0.492	2.7273	0.3618	0.50	
LH 7 SRR99_HF.T2W	0.316	0.430	2.4536	0.3627	0.50	
MR 11 SRR99_MR.T2W	0.369	0.985	2.8209	0.3900	0.50	
LS 12 SRR99_SF.T2W	0.316	0.430	3.6318	0.3844	0.50	
RH 8 SRR99_HV.T2W	0.290	0.381	1.3833	0.4464	0.50	
RJ 10 SRR99_JV.T2W	0.342	0.493	1.3472	0.4462	0.50	
RS 13 SRR99_SV.T2W	0.282	0.381	1.3764	0.4486	0.50	
Total Areas		2.119	3.591			

=====

## Divider Summary

ID Name	# #	Divider Area (ft2)	DivEdge Area (ft2)	Udiv (Btu/h-ft2-F)	Udivedge (Btu/h-ft2-F)	Abs Spacer	Info
7 SRR99_DV.T2W	2 2	0.922	2.647	0.6486	0.3530	0.50	
7 SRR99_DV.T2W	2 2	0.879	2.452	0.6486	0.3530	0.50	
Total Areas		1.800	5.099				

=====

## Glazing System Detail ID: 11 'dhs-gl' Total Cavity: 0.492"

ID	Name	D(in)	Tsol	Asol	1 Emis	2 1 Temp	F 2
5142	S100CL_3.PPG	# 0.129	.56	.231	.096	.843	3.8 4.2
	8 Air/Argon/Kryp	0.492					
5009	CLEAR_3.PPG	0.129	.82	.056	.840	.840	55.7 56.1

=====

# 1-B. Aluminum Horizontal Slider With Dividers (Detailed Radiation Model)

## 1-B-1. WINDOW 4.1 Report

WINDOW 4.1 Report  
 ID:5  
 Name:SRR99dr-hsld  
 Mode:Design  
 EnvCond:1  
  
 Type:Horz Slider  
 Tilt: 90  
 Size:Horz Slid AA  
 Width: 60.00"  
 Height: 36.00"  
 Area: 15.00 ft2  
  
 U-value: 0.597 Btu/h-ft2-F  
 SC: 0.526  
 SHGC: 0.452  
 Vt: 0.551

Page 1 01/05/01 09:10:18  
 FrID: 14 FrID: 15  
 =====  
	GlzSysID: 11		GlzSysID: 11	
	Wid:29.46"		Wid:26.63"	
	Div ID: 7		Div ID: 7	
	#H: 2 #V: 2		#H: 2 #V: 2	
	FrID: 18			
 =====  
 FrID: 19 FrID: 20

### Data for Glazing Systems

ID	Name	COG Area ft2	#Lay	Tilt	Uc Btu/h-ft2	SCc	SHGCc	Vtc	RHG
11	dhs-gl	1.349	2	90	0.272	0.62	0.53	0.75	128
11	dhs-gl	1.040	2	90	0.272	0.62	0.53	0.75	128

### Glass and Gas Data for Glazing System '11 dhs-gl'

ID	Name	D(in)	Tsol	1 Rsol	2 Tvis	1 Rvis	2 Tir	1 Emis	2 Keff
Outside									
5142FS100CL_3.PPG	#	0.129	.566	.210	.270	.827	.061 .046	.000 .843	.096 .520
8	Air/Argon/Kryp	0.492	Air:	10%	Ar:	90%	Kr:	0%	.015
5009	CLEAR_3.PPG	0.129	.827	.076	.076	.898	.086 .086	.000 .840	.840 .520
Inside									

### Frame Data

Location	ID	Name	Source	Frame Area ft2	Edge Area ft2	Uframe Btu/h-ft2-F	Uedge
Left Jamb	16	SR99R_JF.T2W	FRAME Jamb	0.210	0.492	2.3244	0.3399
Left Header	14	SR99R_HF.T2W	FRAME Head	0.316	0.430	2.0176	0.3488
Mullion	18	SR99R_MR.T2W	FRAME Rail	0.369	0.985	2.1548	0.3874
Left Sill	19	SR99R_SF.T2W	FRAME Sill	0.316	0.430	2.7300	0.3669
Right Header	15	SR99R_HV.T2W	FRAME Head	0.290	0.381	1.2738	0.4395
Right Jamb	17	SR99R_JV.T2W	FRAME Jamb	0.342	0.493	1.2398	0.4393
Right Sill	20	SR99R_SV.T2W	FRAME Sill	0.282	0.381	1.2676	0.4414

ID	Name	Source	Divider Area ft2	Edge Area ft2	Udiv Btu/h-ft2-F	Udivedge Btu/h-ft2-F
7	SRR99_DV.T2W	FRAME Divide	0.921	2.646	0.6486	0.3530
7	SRR99_DV.T2W	FRAME Divide	0.879	2.452	0.6486	0.3530

Gas Data

ID	Name	Cond Btu/h-ft-F	dCond Btu/h-ft-F2	Visc lb-s/ft2	dVisc lb-s/ft2-F	Dens lb/ft3	dDens lb/ft3-F	Pran	dPran
			x e-5	x e-5	x e-8				
8	Air/Argon/Kryp	Air: .0101	10% 1.7324	Argon: 0.0442	90% 0.0756	Kryp: 0.1081	0% -0.0002	.6840	.00043

No gas data for Single Glazing

Environmental Conditions: 1 NFRC/ASHRAE

	Tout (F)	Tin (F)	WndSpd (mph)	Wnd Dir	Solar (Btu/h-ft2)	Tsky	Esky (F)
Uvalue	0.0	70.0	15.00	Windward	0.0	0.0	1.00
Solar	89.0	75.0	7.50	Windward	248.2	89.0	1.00

Frame Library Data

ID	Name	Source	U-value Frame Btu/h-ft2-F	U-value Edge Btu/h-ft2-F	Edge Corr	GlzSys Width in	GlzSys Uc Btu/h-ft2-F	Width (PFD) in	Abs
16	SR99R_JF.T2W	FRAME Jamb	2.32	0.34	N/A	0.7500	0.272	0.875	0.50
14	SR99R_HF.T2W	FRAME Head	2.02	0.35	N/A	0.7500	0.272	1.481	0.50
18	SR99R_MR.T2W	FRAME Rail	2.15	0.39	N/A	0.7500	0.272	1.607	0.50
19	SR99R_SF.T2W	FRAME Sill	2.73	0.37	N/A	0.7500	0.272	1.481	0.50
15	SR99R_HV.T2W	FRAME Head	1.27	0.44	N/A	0.7500	0.272	1.484	0.50
17	SR99R_JV.T2W	FRAME Jamb	1.24	0.44	N/A	0.7500	0.272	1.426	0.50
20	SR99R_SV.T2W	FRAME Sill	1.27	0.44	N/A	0.7500	0.272	1.441	0.50

ID	Name	Source	U-value		Edge Corr	GlzSys Width in	GlzSys Uc Btu/h- ft2-F	Width (PFD) in	Abs
			Div Btu/h- ft2-F	Edge Btu/h- ft2-F					
7	SRR99_DV.T2W	FRAME Divide	0.65	0.35	N/A	0.7500	0.272	1.100	0.50

Optical Properties for Glazing System '11 dhs-gl'

Angle    0    10    20    30    40    50    60    70    80    90    Hemis

Vtc : 0.746  
 Rf : 0.120  
 Rb : 0.124

Tsol : 0.474  
 Rf : 0.239  
 Rb : 0.269

Abs 1: 0.231  
 Abs 2: 0.056  
 Abs 3:  
 Abs 4:  
 Abs 5:  
 Abs 6:  
 SHGCc: 0.534

SCc: 0.62 Color Properties    DomWL    Purity    L\*    a\*    b\*  
 Tdw: N/A Transmittance    um    %  
 Tuv: N/A Reflectance    um    %

Temperature Distribution (degrees F) for '11 dhs-gl'

Env. Conditions:	1 NFRC/ASHRAE	U-value	Condensation		Solar
			RH		
	Outside Air	0.0			89.0
	Outer Surface	3.8	N/A		102.2
Layer 1	Center	4.0			102.7
	Inner Surface	4.2			102.7
	Outer Surface	55.7			88.7
Layer 2	Center	55.9			88.6
	Inner Surface	56.1	61.3%		88.4
	Inside Air	70.0			75.0

# 1-B-2. NFRC Report

WINDOW 4.1 NFRC Report Page 1/1 01/05/01 09:10:31  
 Library Path: R:\NFRC\ROUNDR~1\SRR99&~1\HORSLID\W4LIB\

=====

ID:	5	W: 60.00"	H: 36.00"	Proj Area: 15.00 ft2
Name:	SRR99dr-hsld	Type: Horz Slider	Vis Trans: 0.55	
U-value:	0.60 Btu/h-ft2-F	SHGC: 0.45		

=====

Glazing System Summary

ID Name	Area(ft2)	Width(in)	Uc (Btu/h-ft2-F)	SHGCc
11 dhs-gl	1.349	0.7500	0.2717	0.53
11 dhs-gl	1.040	0.7500	0.2717	0.53
Total COG Area		2.388		

=====

## Frame Summary

Part ID Name	Frame Area (ft2)	Edge Area (ft2)	Uframe (Btu/h-ft2-F)	Uedge (Btu/h-ft2-F)	Abs Spacer	Info
LJ 16 SR99R_JF.T2W	0.210	0.492	2.3244	0.3399	0.50	
LH 14 SR99R_HF.T2W	0.316	0.430	2.0176	0.3488	0.50	
MR 18 SR99R_MR.T2W	0.369	0.985	2.1548	0.3874	0.50	
LS 19 SR99R_SF.T2W	0.316	0.430	2.7300	0.3669	0.50	
RH 15 SR99R_HV.T2W	0.290	0.381	1.2738	0.4395	0.50	
RJ 17 SR99R_JV.T2W	0.342	0.493	1.2398	0.4393	0.50	
RS 20 SR99R_SV.T2W	0.282	0.381	1.2676	0.4414	0.50	
Total Areas		2.124	3.591			

=====

## Divider Summary

ID Name	# #	Divider Area (ft2)	DivEdge Area (ft2)	Udiv (Btu/h-ft2-F)	Udivedge (Btu/h-ft2-F)	Abs Spacer	Info
7 SRR99_DV.T2W	2 2	0.921	2.646	0.6486	0.3530	0.50	
7 SRR99_DV.T2W	2 2	0.879	2.452	0.6486	0.3530	0.50	
Total Areas		1.800	5.098				

=====

## Glazing System Detail ID: 11 'dhs-gl' Total Cavity: 0.492"

ID	Name	D(in)	Tsol	Asol	1 Emis	2 1 Temp	F 2
5142	S100CL_3.PPG	# 0.129	.56	.231	.096	.843	3.8 4.2
	8 Air/Argon/Kryp	0.492					
5009	CLEAR_3.PPG	0.129	.82	.056	.840	.840	55.7 56.1

=====

## 2-A. Aluminum Horizontal Slider Without Dividers (Standard NFRC Model)

### 2-A-1. WINDOW 4.1 Report

WINDOW 4.1 Report

ID:2

Name:srr99-hsld

Mode:Design

EnvCond:1

Type:Horz Slider

Tilt: 90

Size:Horz Slid AA

Width: 60.00"

Height: 36.00"

Area: 15.00 ft2

U-value: 0.582 Btu/h-ft2-F

SC: 0.595

SHGC: 0.512

Vt: 0.640

Page 1

01/05/01 09:03:51

FrID: 7

FrID: 8

FrID: 9

```

=====
||| GlzSysID: 11 ||| GlzSysID: 11 |||
||| Wid:28.06" ||| Wid:28.06" |||
||| Div ID: 0 ||| Div ID: 0 |||
|||                                     |||
|||                                     ||| FrID: 11 |||
|||                                     |||
=====
FrID: 12           FrID: 13
    
```

FrID: 10

#### Data for Glazing Systems

ID	Name	COG Area ft2	#Lay	Tilt	Uc Btu/h-ft2	SCc	SHGCc	Vtc	RHG
11	dhs-gl	4.490	2	90	0.272	0.62	0.53	0.75	128
11	dhs-gl	4.495	2	90	0.272	0.62	0.53	0.75	128

#### Glass and Gas Data for Glazing System '11 dhs-gl'

ID	Name	D(in)	Tsol	1 Rsol	2 Tvis	1 Rvis	2 Tir	1 Emis	2 Keff
Outside									
5142FS100CL_3.PPG	#	0.129	.566	.210	.270	.827	.061	.046	.000
8	Air/Argon/Kryp	0.492	Air:	10%	Ar:	90%	Kr:	0%	.015
5009	CLEAR_3.PPG	0.129	.827	.076	.076	.898	.086	.086	.000
Inside									

#### Frame Data

Location	ID	Name	Source	Frame Area ft2	Edge Area ft2	Uframe Btu/h-ft2-F	Uedge
Left Jamb	9	SRR99_JF.T2W	FRAME Jamb	0.205	0.530	2.7273	0.3618
Left Header	7	SRR99_HF.T2W	FRAME Head	0.301	0.444	2.4536	0.3627
Mullion	11	SRR99_MR.T2W	FRAME Rail	0.369	1.061	2.8209	0.3900
Left Sill	12	SRR99_SF.T2W	FRAME Sill	0.301	0.444	3.6318	0.3844
Right Header	8	SRR99_HV.T2W	FRAME Head	0.305	0.444	1.3833	0.4464
Right Jamb	10	SRR99_JV.T2W	FRAME Jamb	0.342	0.531	1.3472	0.4462
Right Sill	13	SRR99_SV.T2W	FRAME Sill	0.296	0.444	1.3764	0.4486

Gas Data

ID	Name	Cond Btu/ h-ft- F	dCond Btu/h- ft-F2	Visc lb-s/ ft2	dVisc lb-s/ ft2-F	Dens lb/ft3	dDens lb/ft3- F	Pran	dPran
		x e-5		x e-5		x e-8			
8	Air/Argon/Kryp	Air: .0101	10% 1.7324	Argon: 0.0442	90% 0.0756	Kryp: 0.1081	0% -0.0002	.6840	.00043

No gas data for Single Glazing

Environmental Conditions: 1 NFRC/ASHRAE

	Tout (F)	Tin (F)	WndSpd (mph)	Wnd Dir	Solar (Btu/h-ft2)	Tsky (F)	Esky (F)
Uvalue	0.0	70.0	15.00	Windward	0.0	0.0	1.00
Solar	89.0	75.0	7.50	Windward	248.2	89.0	1.00

Frame Library Data

ID	Name	Source	U-value		Edge Corr	GlzSys Width	GlzSys Uc	Width (PFD)	Abs
			Frame Btu/h- ft2-F	Edge Btu/h- ft2-F		in	Btu/h- ft2-F	in	
9	SRR99_JF.T2W	FRAME Jamb	2.73	0.36	N/A	0.7500	0.272	0.853	0.50
7	SRR99_HF.T2W	FRAME Head	2.45	0.36	N/A	0.7500	0.272	1.481	0.50
11	SRR99_MR.T2W	FRAME Rail	2.82	0.39	N/A	0.7500	0.272	1.607	0.50
12	SRR99_SF.T2W	FRAME Sill	3.63	0.38	N/A	0.7500	0.272	1.481	0.50
8	SRR99_HV.T2W	FRAME Head	1.38	0.45	N/A	0.7500	0.272	1.484	0.50
10	SRR99_JV.T2W	FRAME Jamb	1.35	0.45	N/A	0.7500	0.272	1.426	0.50
13	SRR99_SV.T2W	FRAME Sill	1.38	0.45	N/A	0.7500	0.272	1.441	0.50

Divider Library Data

ID	Name	Source	U-value		Edge Corr	GlzSys Width	GlzSys Uc	Width (PFD)	Abs
			Div Btu/h- ft2-F	Edge Btu/h- ft2-F		in	Btu/h- ft2-F	in	

No Dividers for this Glazing System

Angle 0 10 20 30 40 50 60 70 80 90 Hemis

Vtc : 0.746  
 Rf : 0.120  
 Rb : 0.124

Tsol : 0.474  
 Rf : 0.239  
 Rb : 0.269

Abs 1: 0.231  
 Abs 2: 0.056  
 Abs 3:  
 Abs 4:  
 Abs 5:  
 Abs 6:  
 SHGCc: 0.534

SCc: 0.62 Color Properties DomWL Purity L\* a\* b\*  
 Tdw: N/A Transmittance um %  
 Tuv: N/A Reflectance um %

Temperature Distribution (degrees F) for '11 dhs-gl'

Env. Conditions:		U-value	Condensation	
			RH	Solar
	Outside Air	0.0		89.0
	Outer Surface	3.8	N/A	102.2
Layer 1	Center	4.0		102.7
	Inner Surface	4.2		102.7
	Outer Surface	55.7		88.7
Layer 2	Center	55.9		88.6
	Inner Surface	56.1	61.3%	88.4
	Inside Air	70.0		75.0

## 2-A-2. NFRC Report

WINDOW 4.1 NFRC Report Page 1/1 01/05/01 09:07:15  
 Library Path: R:\NFRC\ROUNDR~1\SRR99&~1\HORSLID\W4LIB\

=====

ID: 2 W: 60.00" H: 36.00" Proj Area: 15.00 ft2  
 Name: srr99-hsld Type: Horz Slider Vis Trans: 0.64  
 U-value: 0.58 Btu/h-ft2-F SHGC: 0.51

=====

Glazing System Summary

ID	Name	Area(ft2)	Width(in)	Uc (Btu/h-ft2-F)	SHGCc
11	dhs-gl	4.490	0.7500	0.2717	0.53
11	dhs-gl	4.495	0.7500	0.2717	0.53
Total COG Area		8.985			

=====

### Frame Summary

Part	ID	Name	Frame Area (ft2)	Edge Area (ft2)	Uframe (Btu/h-ft2-F)	Uedge (Btu/h-ft2-F)	Abs Spacer	Info
LJ	9	SRR99_JF.T2W	0.205	0.530	2.7273	0.3618	0.50	
LH	7	SRR99_HF.T2W	0.301	0.444	2.4536	0.3627	0.50	
MR	11	SRR99_MR.T2W	0.369	1.061	2.8209	0.3900	0.50	
LS	12	SRR99_SF.T2W	0.301	0.444	3.6318	0.3844	0.50	
RH	8	SRR99_HV.T2W	0.305	0.444	1.3833	0.4464	0.50	
RJ	10	SRR99_JV.T2W	0.342	0.531	1.3472	0.4462	0.50	
RS	13	SRR99_SV.T2W	0.296	0.444	1.3764	0.4486	0.50	
Total Areas			2.119	3.897				

=====

### Divider Summary

No Dividers Defined

=====

Glazing System Detail ID: 11 'dhs-gl' Total Cavity: 0.492"

ID	Name	D(in)	Tsol	Asol	1	Emis	2	1	Temp	F	2
5142	S100CL_3.PPG	# 0.129	.56	.231	.096	.843		3.8		4.2	
	8 Air/Argon/Kryp	0.492									
5009	CLEAR_3.PPG	0.129	.82	.056	.840	.840		55.7		56.1	

=====

## 2-B. Aluminum Horizontal Slider W/O Dividers (Advanced Radiation Model)

### 2-B-1. WINDOW 4.1 Report

WINDOW 4.1 Report

Page 1

01/05/01 09:13:36

ID:4  
 Name:srr99r-hsld  
 Mode:Design  
 EnvCond:1

FrID: 14 FrID: 15

Type:Horz Slider  
 Tilt: 90  
 Size:Horz Slid AA  
 Width: 60.00"  
 Height: 36.00"  
 Area: 15.00 ft2

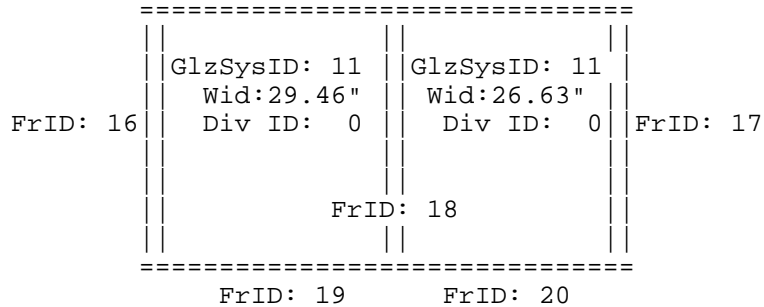

U-value: 0.527 Btu/h-ft2-F  
 SC: 0.585  
 SHGC: 0.503  
 Vt: 0.640

#### Data for Glazing Systems

ID	Name	COG Area ft2	#Lay	Tilt	Uc Btu/h-ft2	SCc	SHGCc	Vtc	RHG
11	dhs-gl	4.763	2	90	0.272	0.62	0.53	0.75	128
11	dhs-gl	4.217	2	90	0.272	0.62	0.53	0.75	128

#### Glass and Gas Data for Glazing System '11 dhs-gl'

ID	Name	D(in)	Tsol	1 Rsol	2 Rsol	Tvis	1 Rvis	2 Rvis	Tir	1 Emis	2 Emis	Keff
Outside												
5142FS100CL_3.PPG	#	0.129	.566	.210	.270	.827	.061	.046	.000	.843	.096	.520
8	Air/Argon/Kryp	0.492	Air:	10%		Ar:	90%		Kr:	0%		.015
5009	CLEAR_3.PPG	0.129	.827	.076	.076	.898	.086	.086	.000	.840	.840	.520
Inside												

#### Frame Data

Location	ID	Name	Source	Frame Area ft2	Edge Area ft2	Uframe Btu/h-ft2-F	Uedge
Left Jamb	16	SR99R_JF.T2W	FRAME Jamb	0.210	0.530	2.3244	0.3399
Left Header	14	SR99R_HF.T2W	FRAME Head	0.316	0.468	2.0176	0.3488
Mullion	18	SR99R_MR.T2W	FRAME Rail	0.369	1.061	2.1548	0.3874
Left Sill	19	SR99R_SF.T2W	FRAME Sill	0.316	0.468	2.7300	0.3669
Right Header	15	SR99R_HV.T2W	FRAME Head	0.290	0.419	1.2738	0.4395
Right Jamb	17	SR99R_JV.T2W	FRAME Jamb	0.342	0.531	1.2398	0.4393
Right Sill	20	SR99R_SV.T2W	FRAME Sill	0.282	0.419	1.2676	0.4414

Gas Data

ID	Name	Cond Btu/ h-ft- F	dCond Btu/h- ft-F2	Visc lb-s/ ft2	dVisc lb-s/ ft2-F	Dens lb/ft3	dDens lb/ft3- F	Pran	dPran
		x e-5		x e-5		x e-8			
8	Air/Argon/Kryp	Air: .0101	10% 1.7324	Argon: 0.0442	90% 0.0756	Kryp: 0.1081	0% -0.0002	.6840	.00043

No gas data for Single Glazing

Environmental Conditions: 1 NFRC/ASHRAE

	Tout (F)	Tin (F)	WndSpd (mph)	Wnd Dir	Solar (Btu/h-ft2)	Tsky (F)	Esky (F)
Uvalue	0.0	70.0	15.00	Windward	0.0	0.0	1.00
Solar	89.0	75.0	7.50	Windward	248.2	89.0	1.00

Frame Library Data

ID	Name	Source	U-value		Edge Corr	GlzSys Width	GlzSys Uc	Width (PFD)	Abs
			Frame Btu/h- ft2-F	Edge Btu/h- ft2-F		in	Btu/h- ft2-F	in	
16	SR99R_JF.T2W	FRAME Jamb	2.32	0.34	N/A	0.7500	0.272	0.875	0.50
14	SR99R_HF.T2W	FRAME Head	2.02	0.35	N/A	0.7500	0.272	1.481	0.50
18	SR99R_MR.T2W	FRAME Rail	2.15	0.39	N/A	0.7500	0.272	1.607	0.50
19	SR99R_SF.T2W	FRAME Sill	2.73	0.37	N/A	0.7500	0.272	1.481	0.50
15	SR99R_HV.T2W	FRAME Head	1.27	0.44	N/A	0.7500	0.272	1.484	0.50
17	SR99R_JV.T2W	FRAME Jamb	1.24	0.44	N/A	0.7500	0.272	1.426	0.50
20	SR99R_SV.T2W	FRAME Sill	1.27	0.44	N/A	0.7500	0.272	1.441	0.50

Divider Library Data

ID	Name	Source	U-value		Edge Corr	GlzSys Width	GlzSys Uc	Width (PFD)	Abs
			Div Btu/h- ft2-F	Edge Btu/h- ft2-F		in	Btu/h- ft2-F	in	

No Dividers for this Glazing System

Angle 0 10 20 30 40 50 60 70 80 90 Hemis

Vtc : 0.746  
 Rf : 0.120  
 Rb : 0.124

Tsol : 0.474  
 Rf : 0.239  
 Rb : 0.269

Abs 1: 0.231  
 Abs 2: 0.056  
 Abs 3:  
 Abs 4:  
 Abs 5:  
 Abs 6:  
 SHGCc: 0.534

SCc: 0.62 Color Properties DomWL Purity L\* a\* b\*  
 Tdw: N/A Transmittance um %  
 Tuv: N/A Reflectance um %

Temperature Distribution (degrees F) for '11 dhs-gl'

Env. Conditions:		U-value	Condensation		Solar
			RH		
	1 NFRC/ASHRAE	0.0			89.0
	Outside Air	3.8			102.2
	Outer Surface	4.0		N/A	102.7
Layer 1	Center	4.2			102.7
	Inner Surface	55.7			88.7
	Outer Surface	55.9			88.6
Layer 2	Center	56.1	61.3%		88.4
	Inner Surface	70.0			75.0
	Inside Air				

## 2-B-2. NFRC Report

WINDOW 4.1 NFRC Report Page 1/1 01/05/01 09:13:45  
 Library Path: R:\NFRC\ROUNDR~1\SRR99&~1\HORSLID\W4LIB\

=====  
 ID: 4 W: 60.00" H: 36.00" Proj Area: 15.00 ft2  
 Name: srr99r-hsld Type: Horz Slider Vis Trans: 0.64  
 U-value: 0.53 Btu/h-ft2-F SHGC: 0.50  
 =====

Glazing System Summary Uc  
 ID Name Area(ft2) Width(in) (Btu/h-ft2-F) SHGCc  
 -----  
 11 dhs-gl 4.763 0.7500 0.2717 0.53  
 11 dhs-gl 4.217 0.7500 0.2717 0.53  
 -----  
 Total COG Area 8.980  
 =====

Frame Summary  
 Part ID Name Frame Area Edge Area Uframe Uedge Abs Spacer Info  
 (ft2) (ft2) (Btu/h-ft2-F)  
 -----  
 LJ 16 SR99R\_JF.T2W 0.210 0.530 2.3244 0.3399 0.50  
 LH 14 SR99R\_HF.T2W 0.316 0.468 2.0176 0.3488 0.50  
 MR 18 SR99R\_MR.T2W 0.369 1.061 2.1548 0.3874 0.50  
 LS 19 SR99R\_SF.T2W 0.316 0.468 2.7300 0.3669 0.50  
 RH 15 SR99R\_HV.T2W 0.290 0.419 1.2738 0.4395 0.50  
 RJ 17 SR99R\_JV.T2W 0.342 0.531 1.2398 0.4393 0.50  
 RS 20 SR99R\_SV.T2W 0.282 0.419 1.2676 0.4414 0.50  
 -----  
 Total Areas 2.124 3.896  
 =====

Divider Summary

No Dividers Defined

=====  
 Glazing System Detail ID: 11 'dhs-gl' Total Cavity: 0.492"

ID Name D(in) Tsol Asol 1 Emis 2 1 Temp F 2  
 -----  
 5142 S100CL\_3.PPG # 0.129 .56 .231 .096 .843 3.8 4.2  
 8 Air/Argon/Kryp 0.492  
 5009 CLEAR\_3.PPG 0.129 .82 .056 .840 .840 55.7 56.1  
 =====

**APPENDIX 2: Autocad drawings**

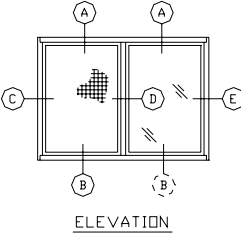
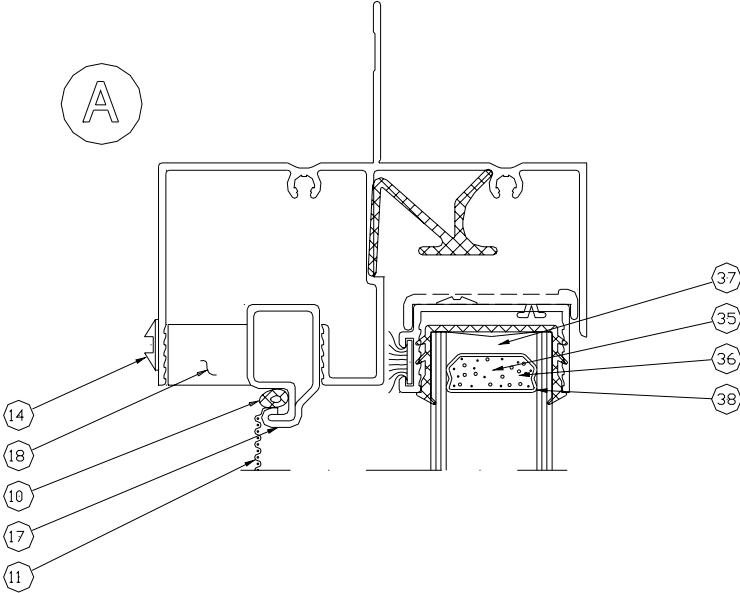

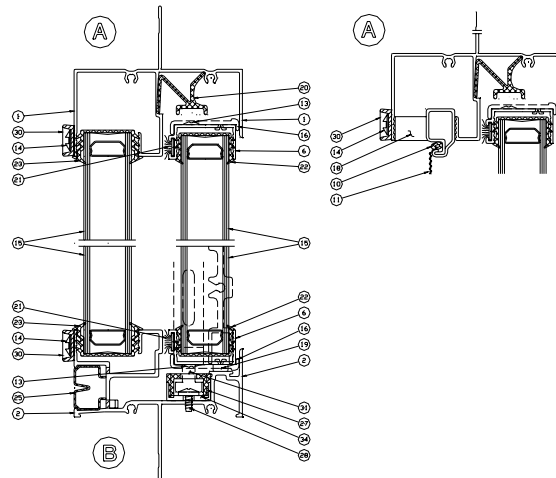

SHEET 2 OF 2

