

## Thermal Comparison of the Trr01 Window with Some Change of the Geometry

Total Ufactor is shown as below: (Btu/h-ft<sup>2</sup>-F)

Ufactor	Trr01	Trr01_0	Trr01_1	Trr01_2
Edge	0.3230	0.3230	0.3248	0.3226
Frame	0.9603	0.9560	0.9257	0.9331

### Relative Difference

Relative_Diff	Trr01_0	Trr01_1	Trr01_2
Edge	0%	0.6%	-0.1%
Frame	-0.4%	-3.6%	-2.8%

Trr01\_2 is using the effective conductivity on both side of the glass.

# Trr01

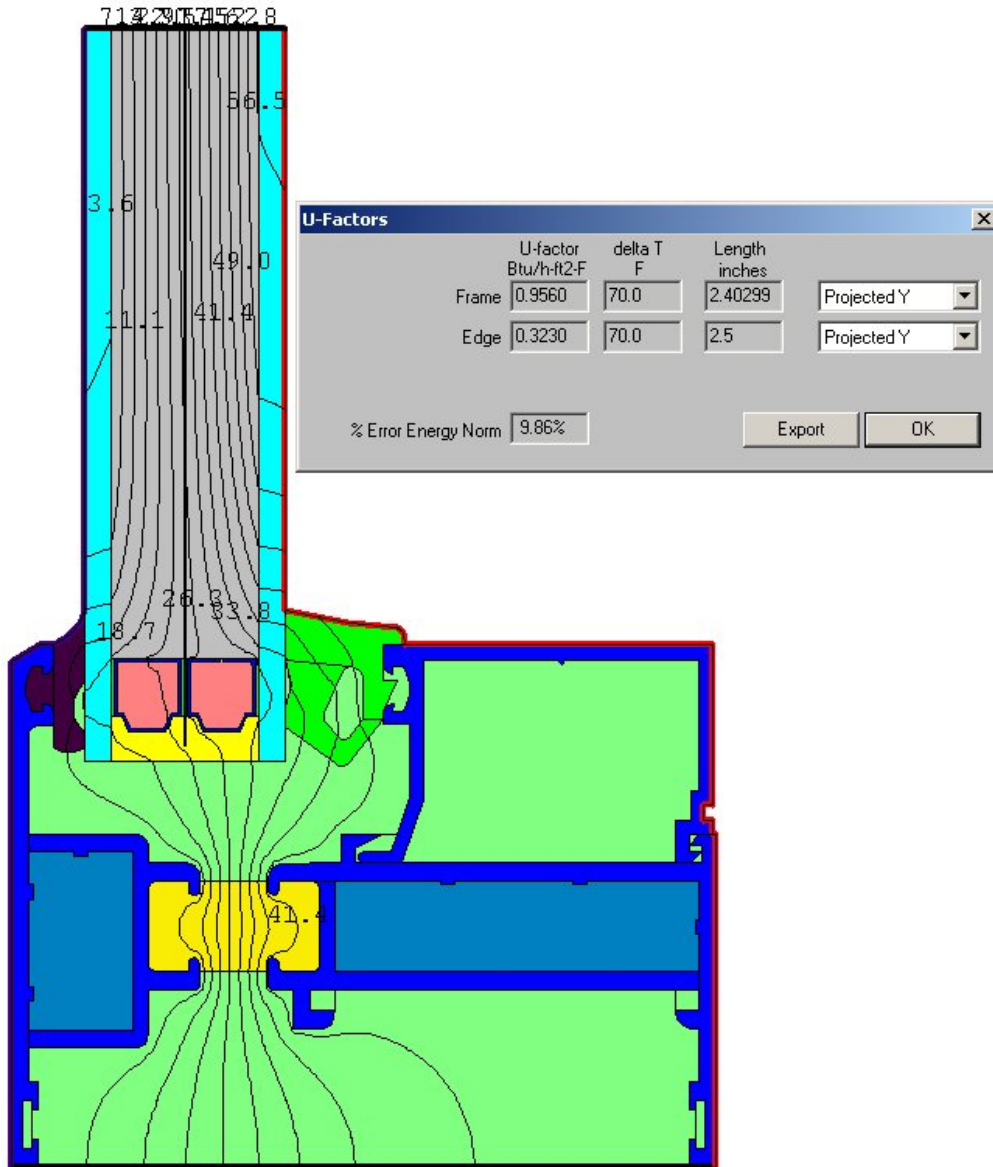

# Trr01\_0

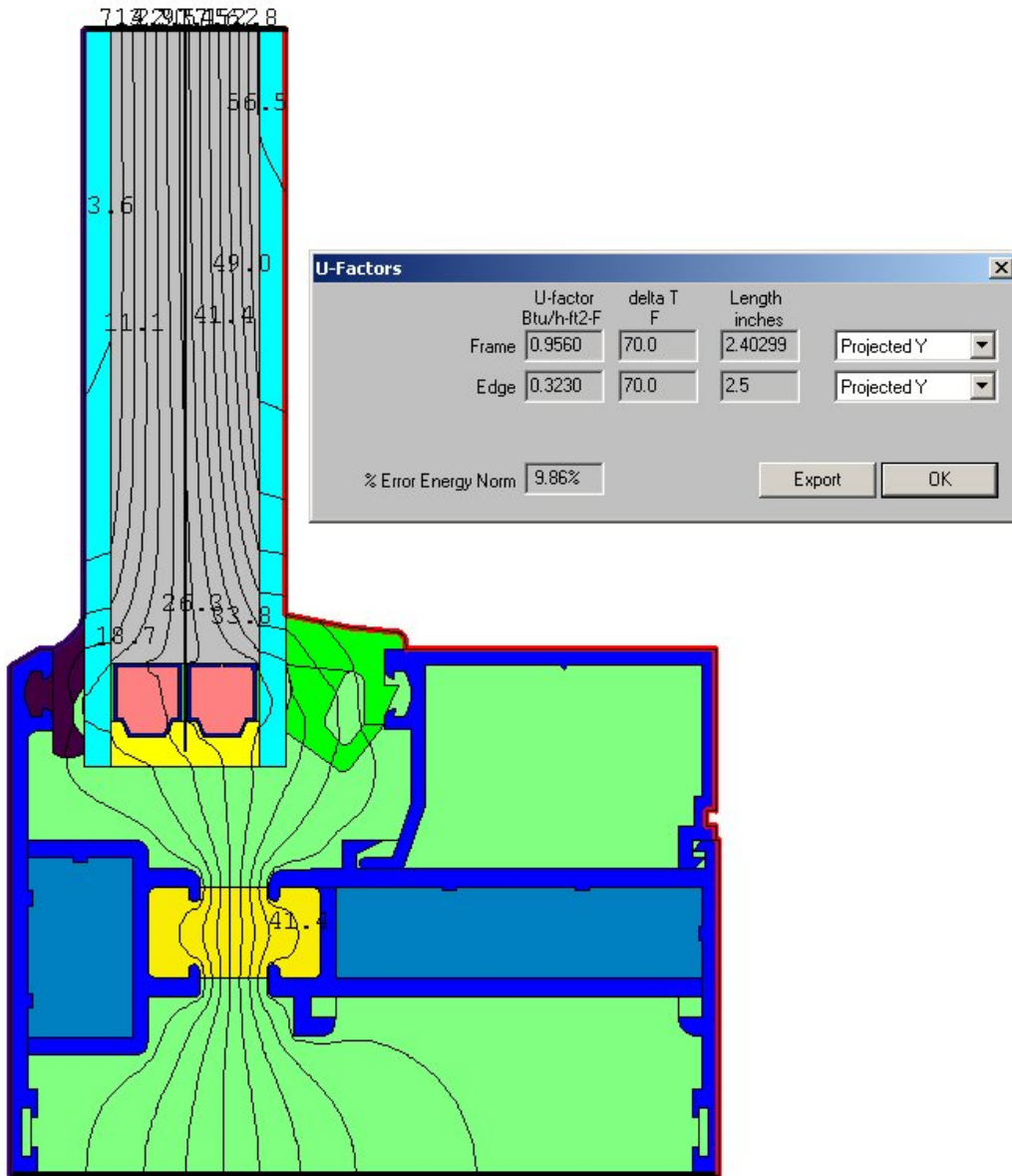

# Trr01\_1

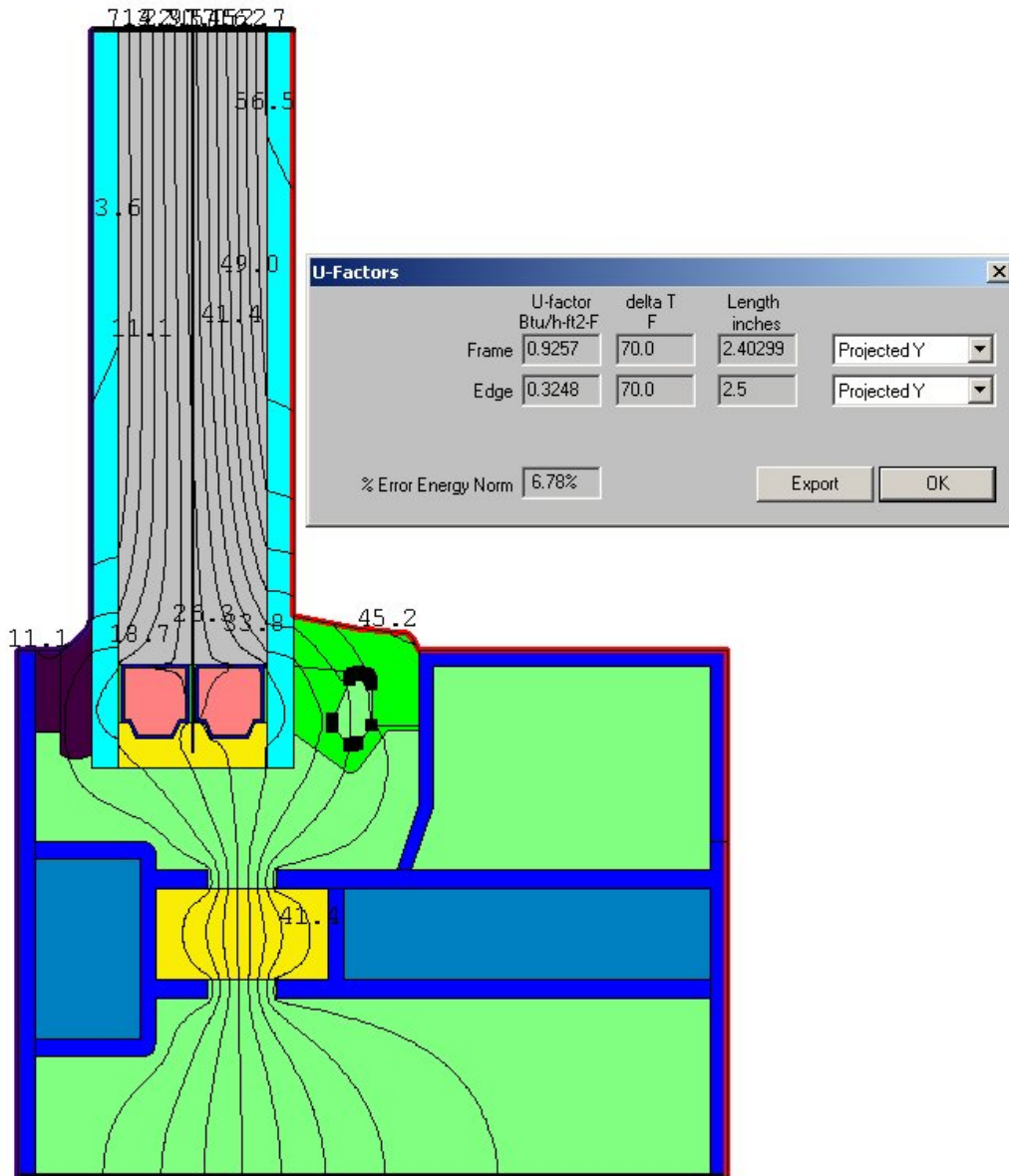

# Trr01\_2

